



# LockView<sup>®</sup> 3.0



# TABLE OF CONTENTS

<b>Introduction</b> .....	3
<b>Components</b> .....	4
<b>Install the LockView® Software</b> .....	5
<b>Operation</b> .....	6
LockView® Login .....	6
Screen Information .....	7
<b>LockView® Options</b> .....	8
<b>Operator Editor</b> .....	10
<b>Lock/User Editor</b> .....	12
User Editor .....	12
Lock Editor .....	14
Access Rights .....	16
Group Editor .....	17
<b>Read/Write Lock</b> .....	19
Connection .....	19
Read Slots .....	20
Audit Trail .....	22
View Temp Log .....	24
Lock Settings .....	26
E3 Temperature Monitoring (if so equipped) .....	26
Write Changes .....	29
Programming Example .....	29
<b>Glossary of Terms</b> .....	35
<b>CompX eLock® Accessories</b> .....	37
<b>Templates</b> .....	38
eLock Cutout Template.....	38
Latch Cutout Template .....	39
Dead Bolt Latch (fractional dimensions).....	40
Dead Bolt Latch (decimal dimensions) .....	41
Slam Bolt Latch (fractional dimensions).....	42
Slam Bolt Latch (decimal dimensions) .....	43
<b>Temperature Monitoring Programming Guide</b> .....	44

## **INTRODUCTION**

An authorized user of LockView® can create a database of users and locks on a local computer. Each user in this “local computer's” database is assigned to a slot in each lock to which they have access. A lock's internal memory is divided into 250 slots that store user information thereby giving each lock a maximum of 250 users.

The local computer with LockView® loaded onto it has the ability to connect to locks and update the lock's memory to correspond with its own database. It is able to gather and manipulate a lock's audit trail, or past operation log. Audit trail information contains the lock's name, the name of the user attempting to gain access, the credential used, if access was granted or denied, and the date and time of each interaction.

On units equipped with temperature monitoring, LockView® allows viewing of temperature logs, graphs and allows manipulation of temperature range settings (see page 27).

# COMPONENTS



**Numeric Keypad**  
EL-2004-KP



**Magstripe Card**  
EL-2004-MS



**Magstripe / Keypad  
Dual System**  
EL-2004-MSKP



**Prox Reader**  
EL-2004-PR



**Prox Reader /  
Keypad Dual System**  
EL-2004-PRKP



**Refrigerator Kit**  
EL-KP-FRKIT, EL-MS-FRKIT, EL-MSKP-FRKIT,  
EL-PR-FRKIT, EL-PRKP-FRKIT



**Refrigerator Kit  
w/ Temperature Monitoring**  
EL-KP-TEMP, EL-MSKP-TEMP, EL-PRKP-TEMP



## INSTALL THE LOCKVIEW® SOFTWARE

1. Insert the LockView® CD into the CD ROM drive.

An install screen appears with three options:

- ➔ Install LockView® v3.0,
- ➔ Install Adobe Acrobat®,
- ➔ LockView® Manual (pdf).

2. Select an option.

3. If the LockView® Software did not autorun:

- ➔ Select Windows **START** button in bottom left corner of computer screen.
- ➔ Select **RUN**.
- ➔ Select **BROWSE**.
- ➔ Look in the appropriate CD ROM drive.
- ➔ Select the "Autorun.exe" file.

4. Follow all the on screen instructions to load program.

5. Plug in the USB adapter to the computer.

- ➔ "Found new hardware" will display. The USB driver for the LockView® USB adapter needs to be installed.

6. Reboot the computer so the USB drivers automatically install.

7. If the USB drivers do not install, follow these steps:

- ➔ Right click on the My Computer icon on desktop. (Vista users right-click on the Computer icon)
- ➔ Select Properties.
- ➔ Select Hardware tab.
- ➔ Select Device Manager.
- ➔ Double click on yellow USB Serial Bus controller.
- ➔ Select tab.
- ➔ Select Update Driver.
- ➔ The computer will need to be restarted after driver installation.
- ➔ Reopen Device Manager and click on Universal Serial Bus controllers to see if Windows is seeing **CompX Fort eLock2 + USB Adapter**.



*The person installing and operating LockView® must have **ADMINISTRATIVE RIGHTS** on the computer where LockView® will be installed.*

## OPERATION

Load the LockView® software. Double click the LockView® icon on the desktop to open and run the LockView® program.



**NOTE:** If the LockView® ODBC entry was not created properly, it will need to be created manually, refer to DATABASE FILE LOCATION on page 9.

### **LOCKVIEW® LOGIN**

For first time login, enter "admin" under both operator name and password, then click OK. Note: Passwords are case sensitive.

- ➔ After an operator has been added to LockView®, use of personalized **Operator Name** and password should be used for login.

**NOTE:** There is NO security while logged in under "admin." The "admin" user should be deleted after new operator name and password have been completed to ensure database security.

Once login is accepted, the opening screen will display and operation of the program can continue.

## OPERATION continued

### SCREEN INFORMATION

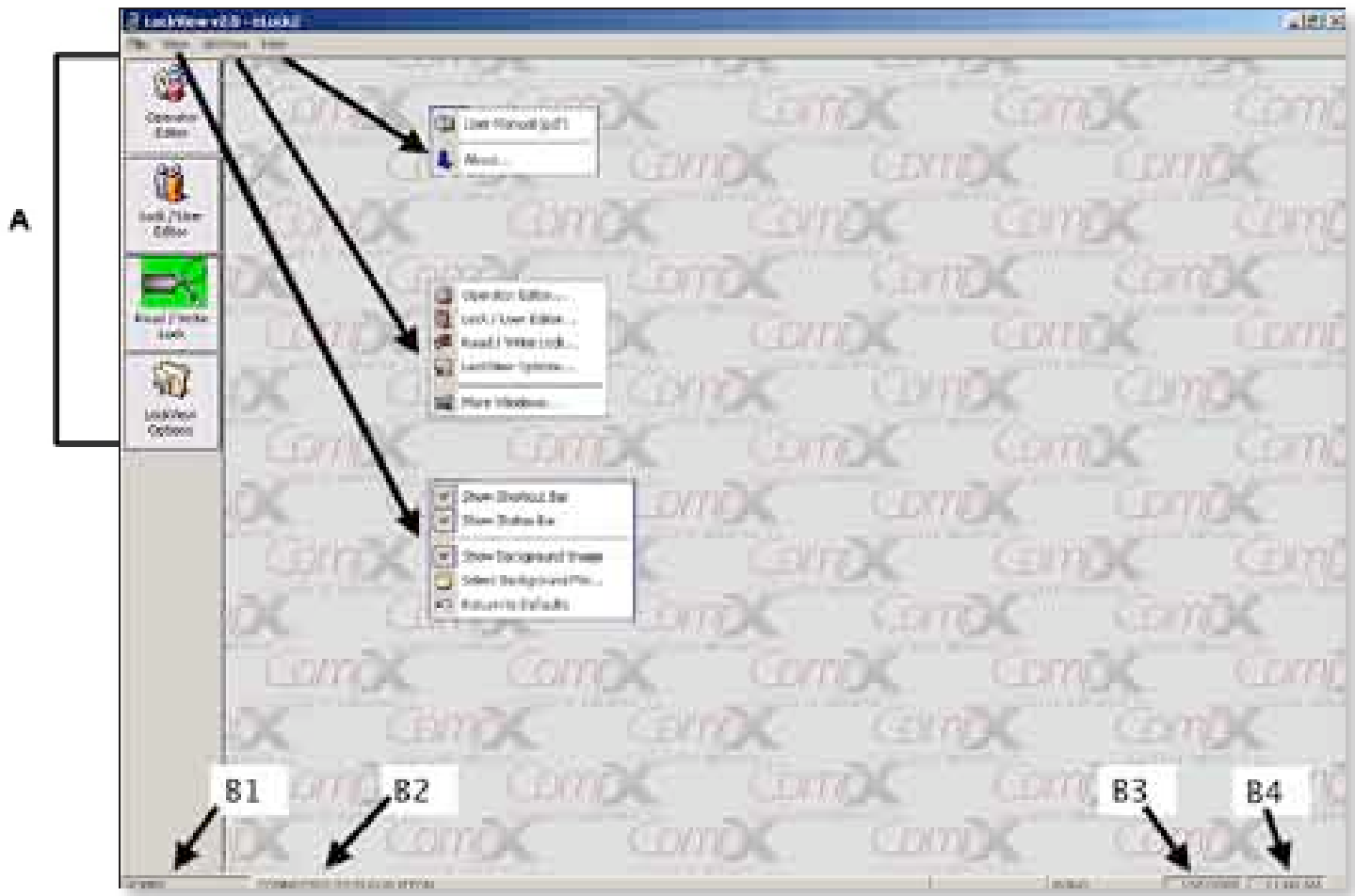

**FILE drop down menu** – Used to EXIT program.

**VIEW drop down menu** – Used to display or eliminate the shortcut and/or status bars on the program screen. Also used to display or eliminate the background image, select another background image from a saved file, or return program to default settings.

**WINDOW drop down menu** – A second way to access these programming menus:

- ➔ Operator Editor,
- ➔ Lock/User Editor,
- ➔ Read/Write Lock,
- ➔ LockView® Options, and
- ➔ More Windows

**HELP drop down menu** – Will open a PDF version of the LockView® Operator's Manual.

**A — SHORTCUT BAR** - Contains quick start buttons for the **Operator Editor**, **Lock/User Editor**, **Read/Write Lock**, and **LockView® options** menus. The shortcut bar can be displayed or hidden, refer to the **VIEW** drop down menu.

**B — STATUS BAR** - Shows LockView® program status information including:

B1 – Current Operator Login Name.

B2 – Connection to lock status. This can also be used as a quick start button to connect/disconnect to a lock for upload or download purposes. Click the box once to connect or disconnect.

B3 – Current local computer date.

B4 – Current local computer time.

The status bar can be displayed or hidden, refer to the View drop down menu.

## LOCKVIEW® OPTIONS

The LockView® Options window allows the operator to make changes to the database location on the computer as well as other changes to the behavior of LockView®.

When the LockView® software is run for the first time, ODBC entry called "LockView®" is created.

If an error occurred while creating the ODBC entry on startup, a prompt will appear to select or create an entry.



1. Select the LockView® Options window.

### COMMUNICATIONS PORT

Select which Com or USB port the LockView® software will run through. The operator can select:

- ➔ COM 1
- ➔ COM 2
- ➔ COM 3
- ➔ COM 4
- ➔ USB

## LOCKVIEW® OPTIONS continued

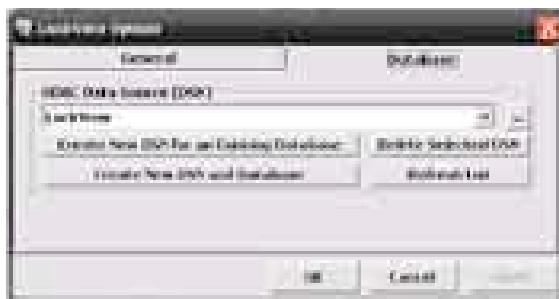

### AUTOMATICALLY SYNCHRONIZE TIME

If Yes is checked, every time LockView® connects to a lock, it will automatically synchronize the eLock's time with the computer time if the time differs by more than 5 minutes.

If No is checked, LockView® will ask the operator to update the eLock's real time clock only if it differs by more than 5 minutes from local computer's clock.

### DAYLIGHT RULES

LockView 3.0 incorporates the ability to adhere to new daylight savings rules

1. Choose Mar-Nov to utilize current daylight savings rule
2. Choose Apr-Oct to utilize old daylight savings rule
3. "Custom" is reserved for any future changes the US Government may institute
4. Daylight savings time (DST) off

### KEEP ALIVE WHILE CONNECTED

1. In almost all applications it is recommended that the "Yes" box is checked.
2. This function is a power saving function in older units that used the RS232 converter.

### DATE FORMAT

1. Choose "mm/dd/yy" for US format (Month, Day, Year)
2. Choose "dd/mm/yy" for International format (Day, Month, Year)

### DATABASE FILE LOCATION

Use this window to change the location of the database file.

If the LockView® ODBC entry was not created properly, it will need to be created manually.

1. Select the database tab from LockView® options window.
2. Press the [...] button to open the ODBC Data Source Administrator
3. Select the user dsn tab and press add.
4. Select Microsoft access driver (\*.mdb) from the list and press finish.
5. The "Data Source Name" field can be given any name, but it is recommended to name it "LockView"
6. The "Description" field can be left blank.
7. Press the select button and select the file named "LockView.mdb", which will be located in your installation path, "C:\Program Files\LockView3.0\"
8. Press OK.

### CREATING MULTIPLE DATABASES

1. Choose "Create New DSN and Database"
2. Insert new DSN with (data source name). Please note that this is the name of the link to the database not the actual database name.
3. Insert new database path (where the database is located i.e. P:\customer\data\list1). Insert the database file name as well as the path.

## OPERATOR EDITOR

The **Operator Editor** window allows the operator to assign new operators to the LockView® software program. These additional operators can be given full access or audit trail rights only. While the **Operator Editor** window is open, one or more operators can be added, edited, or deleted, as necessary.

- ➔ The deletion of the logged in operator is prohibited.

**NOTE:** After the first operator is added to LockView®, it is important to logout and login as the new operator, and then delete the “admin” operator.

**NOTE:** First operator added to LockView® should be given full access rights, not audit trail rights only.



### TO ADD A NEW OPERATOR

1. Select the **Operator Editor** window.
2. Select **Add Operator** to create a new operator.
3. Enter the new operator's name and password.
  - ➔ Password needs to be entered twice for verification.
  - ➔ If **Audit Trail Rights Only** is chosen, that operator will only be able to retrieve and view audit trails.

**NOTE:** Passwords are case sensitive and must be a minimum of 4 characters.



## **OPERATOR EDITOR continued**

4. Select OK when done.
5. Select Close to close the Operator Editor tab.

### **TO EDIT AN OPERATOR**

1. Select the **Operator Editor** window.
2. Select **Operator Name** and then select **Edit Operator** to edit an operator's information.
3. Select OK when done.
4. Select Close to close the **Operator Editor** tab.

### **TO DELETE AN OPERATOR**

1. Select the **Operator Editor** window.
2. Select **Operator Name** and then select **Delete Operator** to delete an existing operator.

**NOTE:** *Deletion of the currently logged in operator is prohibited.*

3. Select Close to close the **Operator Editor** tab.

## LOCK / USER EDITOR

The Lock/User Editor window allows the operator to modify the lock and local computer databases.

### USER EDITOR

The User Editor tab is used to add, edit or delete users from the local computer database.

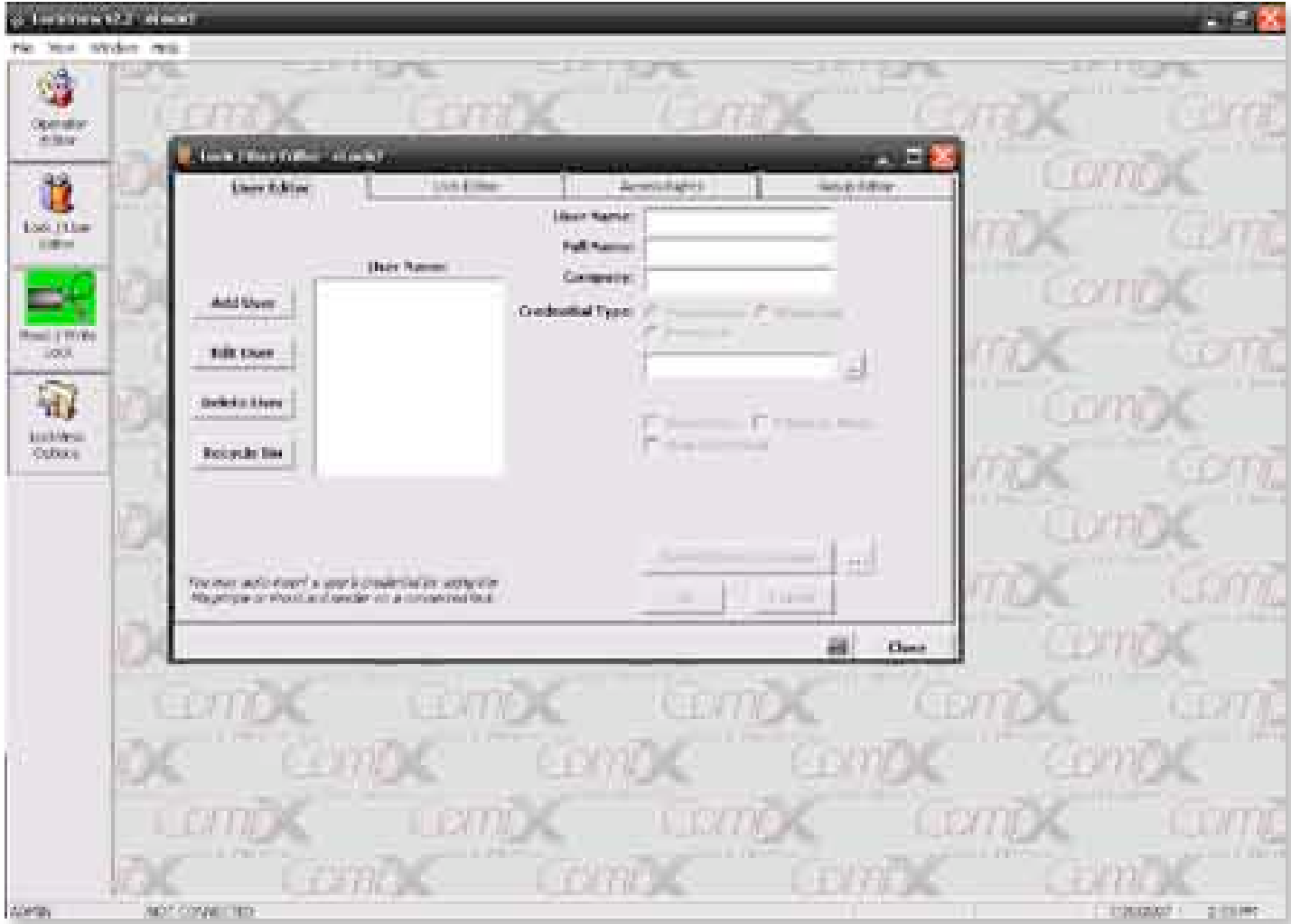

### TO ADD A NEW USER

1. Select the **Lock/User Editor** window.
  - ➔ If the **Lock/User Editor** window is already open, make sure the **User Editor** is open. If not, select the **User Editor** tab.
2. Select **Add User** to create a new user in the local computer database.
3. Enter the new user's personal information.
  - ➔ User Name must be between 4 and 14 characters in length
4. Enter the new user's credential information.
  - ➔ If the user is to have a PIN credential, press the more info button [...] next to the pushbutton PIN # field to automatically generate a random PIN number 4 to 14 digits long or manually enter PIN #.
  - ➔ If an eLock is connected at the time, and it is equipped with a magstripe or HID prox reader, scan the magstripe or prox card to automatically enter this information.
  - ➔ If you wish to manually input a HID proximity credential, this can be done by selecting ProxCard and hitting the more info button [...]. You will need to know the HID facility code, card number, and bit format in order to manually input a proximity code. CompX will not know this information, please refer to your IT Department.

**NOTE:** Use of the more info button [...] is optional and not required to generate a PIN or HID prox credential.

## LOCK / USER EDITOR continued

- ➔ Choose the HID format (26,34,35 or 37 bit)
- ➔ Enter the **Facility Code** (if that format has a facility code)
- ➔ Enter the **Card Number**
- ➔ The hexadecimal number corresponding to that format, **Facility Code**, and **Card Number** will appear in the box. Clicking OK will automatically transfer that number into the **User Editor** in the proper spot.
- ➔ A user can have one “primary” credential (PIN, prox card, or mag stripe) but could have a secondary PIN credential if they have dual credential rights.



**NOTE:** If a user only has a HID prox card credential, they cannot be added to a lock that uses a mag stripe. If a user only has a mag stripe credential, they cannot be added to a lock that uses a HID prox card.

**NOTE:** Two users cannot have the same PIN, HID prox or magstripe credential, this includes users in the recycle bin. If a credential is “recycled,” the person who previously had the credential must be completely removed from the program, including from the recycle bin.

5. If the new user has supervisor rights, check the Supervisor box next to the credential information being supplied.
  - ➔ Supervisor rights are especially useful for programming locks without the LockView® software.
6. If the new user has passage mode rights, check the **Passage Mode** box next to the credential information being supplied.
  - ➔ Passage mode allows the lock to change it's state (lock/unlock) by pressing # after any user with passage mode rights has shown their credential.
7. If the new user has dual credential rights, check the Dual Credential box next to the credential information being supplied.
  - ➔ Dual credential users are users that are required to show two separate credentials to a lock before it will open.
  - ➔ Dual credential users must use an additional number after their primary credential information is given to open a lock.
  - ➔ If the user has a PIN/PIN dual credential, the PIN numbers must be different.
  - ➔ Primary and secondary PINs are NOT interchangeable.
8. If the new user has day and time restrictions to access a lock, select Restrictions & Groups to open the Day/Time Restrictions screen.

**NOTE:** The next screen image below is a new user's restrictions being added to the local computer database.

**Example:** This new user has access to locks on Monday, Tuesday, and Thursday with Thursday being a late shift that ends Friday morning.

9. Fill in the time slots the new user can access the locks, or check the all day box if the user has 24 hour access.
  - ➔ When filling in time slots, LockView® will automatically wrap a day. (Example: 11 p.m. Monday - 7 a.m. Tuesday.)
10. Select OK when done.
11. Select OK when done with Day/Time Restrictions.
12. Select OK when done.
  - ➔ If Invalid message appears, the credential trying to be used is already taken by another user.
13. Select Close to close the user editor tab.

### TO EDIT A USER

1. Select the **Lock/User Editor** window.
  - ➔ If the **Lock/User Editor** window is already open, make sure the user editor is open. If not, select the **User Editor** tab.



## LOCK / USER EDITOR continued

2. Select **User Name** and then select **Edit User** to edit the user's information.
3. Select **OK** when done.
  - ➔ Any changes made to a user must be uploaded into the locks to which the user has access.
4. Select **Close** to close the User Editor tab.

### TO DELETE A USER

1. Select the **Lock/User Editor** window.
  - ➔ If the **Lock/User Editor** window is already open, make sure the user editor is open. If not, select the User Editor tab.

**NOTE:** Before deleting a user, it is recommended the user's access rights be removed from all locks. This ensures the user is deleted and will not be accidentally reinstated into the local computer database.

2. Select **User Name** and then select **Delete User** to delete an existing user from the local computer database.
  - ➔ When a user is deleted from the **User Editor**, they are moved to the **Recycle Bin**.
3. Select **Close** to close the **User Editor** tab.

### RECYCLE BIN

If a user is deleted from the program database, they are moved into the **Recycle Bin**. Once in the **Recycle Bin**, the user can either be restored to the database or completely deleted from the database.

**NOTE:** Two users cannot have the same PIN, HID prox or magstripe credential, this includes users in the recycle bin. If a credential is "recycled", the person who previously had the credential must be completely removed from the program, including from the **Recycle Bin**.

## LOCK EDITOR

The **Lock Editor** tab is used to add, edit, or delete locks from the database.

### TO ADD A NEW LOCK

1. Select the **Lock/User Editor** window.
  - ➔ If the **Lock/User Editor** window is already open, make sure the **Lock Editor** is open. If not, select the **Lock Editor** tab.
2. Select **Add Lock** to create a new lock in the database.
3. Enter a name for the new lock being created.
  - ➔ **Lock Name** must be between 4 and 14 characters in length including spaces.
4. Enter the lock's serial and passcode numbers.
  - ➔ The lock's serial and passcode numbers are on a sticker included with the lock.

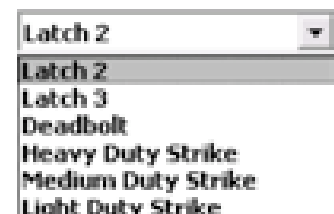
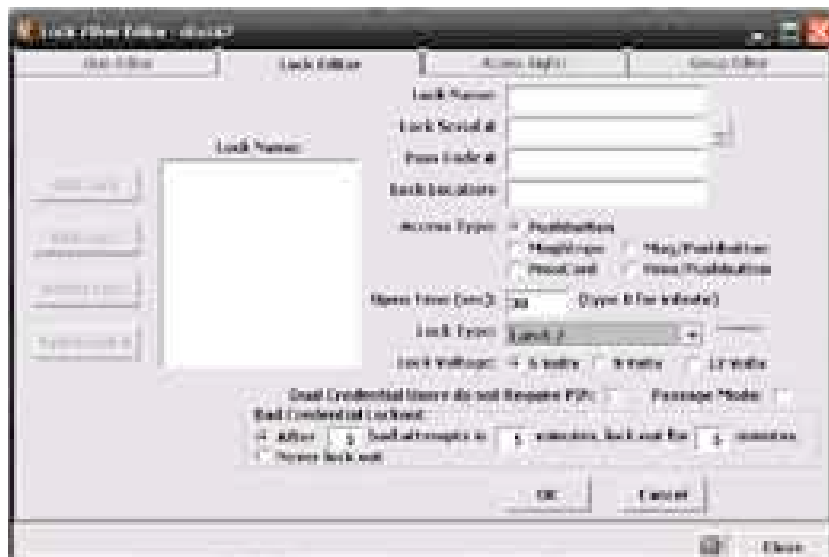

## LOCK / USER EDITOR continued

- ➔ The lock location can also be entered if desired.
- ➔ If the lock is connected at the time, press the more info button [...] next to the **Lock Serial #** field to automatically enter the serial number from the lock.
- 5. Check the **Magstripe, Prox Card, Magstripe/Pushbutton, or Prox card/Pushbutton** box if the lock being entered is provided with one of these user interfaces.
  - ➔ It is not possible to edit a lock's mag stripe or prox card status. If the status needs to be changed, the lock must be deleted and remade with the appropriate interface checked.
- 6. Enter the number of seconds to program how long the latch will stay open.
- 7. Select the type of lock in the **Lock Type** box.
  - ➔ If a 12 volt strike is connected, select the smallest size lock voltage that will keep the internal solenoid pulled in after it opens. This will save on battery power.
  - ➔ If a 12 volt strike is connected, the primary battery power must be 12 volts.
  - ➔ "Latch 2" is the older style CompX elatch. "Latch 3" is the new eLatch.
- 8. Check the **Lock Voltage** box for the appropriate voltage for the lock.
  - ➔ Lock voltage selection will determine the low battery indicator threshold. If this is set incorrectly, the low battery indicator will not function properly.
- 9. If the new lock has passage mode, check the **Passage Mode** box next to the lock type information being supplied.
  - ➔ Passage mode allows the lock to change it's state (lock/unlock) after any user's credential has been shown for that lock.
- 10. If the new lock has dual credential capabilities and you do not wish dual credential users to have to enter both credentials, check the **Dual Credential Users do not Require PIN** box. This will allow dual credentials users to access the lock by showing their primary credential only.
  - ➔ Any dual credential users in the new lock database will only have to provide their primary credential to open a lock, they are not required to enter a secondary PIN.
- 11. Each lock is provided with an incorrect credential lockout feature, called a **Bad Credential Lockout**. The factory default setting is: If 5 invalid credentials are presented to the lock within 5 minutes time, the lock will NOT accept any valid credential or reset code for a period of 5 minutes. If the number of incorrect credentials or either of the time periods need to be adjusted, enter the desired number of credentials or minutes desired in the appropriate boxes.

**NOTE:** To turn this feature off, check the **Never Lockout** box.

- 12. Select **OK** when done.

**NOTE:** The lock's internal memory must match the database for:

- ➔ access type
- ➔ lock type
- ➔ open time
- ➔ dual user does not require PIN
- ➔ lock voltage
- ➔ bad credential lockout

To review the lock settings and database information, open the **Lock Settings** tab under **Read/Write Lock** and update as necessary.

- 13. Select **Close** to close the **Lock Editor** tab.

### TO EDIT AN EXISTING LOCK

- 1. Select the **Lock/User Editor** window.
  - ➔ If the **Lock/User Editor** window is already open, make sure the lock editor is open. If not, select the **Lock Editor** tab.

## LOCK / USER EDITOR continued

2. Select Lock Name and then select **Edit Lock** to edit a lock's information.
  - ➔ A lock's access type and dual credential status cannot be edited.
3. Select **OK** when done.

**NOTE:** The lock's internal memory must match the database for:

- ➔ access type,
- ➔ lock type,
- ➔ open time,
- ➔ dual user does not require PIN
- ➔ lock voltage
- ➔ bad credential lockout

To review the lock settings and database information, open the **Lock Settings** tab under **Read/Write Lock** and update as necessary.

4. Select **Close** to close the Lock Editor tab.

### TO DELETE A LOCK

1. Select the **Lock/User Editor** window.
  - ➔ If the **Lock/User Editor** window is already open, make sure the **Lock Editor** is open. If not select the **Lock Editor** tab.

**NOTE:** Before deleting a lock, it is recommended to remove all access rights to the lock from all users. This ensures the lock is deleted and will not be accidentally reinstated.

2. Select Lock Name and then select **Delete Lock** to delete an existing lock from the local computer database.
3. Select **Close** to close the **Lock Editor** tab.

### ACCESS RIGHTS

The **Access Rights** tab is used to choose which locks the users can have access to in the database. Each lock is limited to a total of 250 users and supervisors.

1. Select the **Access Rights** tab from the **Lock/User Editor** window.

**NOTE:** Select **User Name** or **Lock Name** to view access rights organized by user name or lock name. In steps 2-4, the window is set for **User Name**.

2. Select the user whose access rights will be modified.
  - ➔ All locks in the left column are locks to which the selected user does not have access.
  - ➔ All locks in the right column without a check mark in the box are locks to which the selected user does not yet have access.
  - ➔ All locks in the right column with a check mark in the box are locks to which the selected user has access.

**NOTE:** An unchecked box in the right column means information has not been uploaded into the lock yet. A write changes operation must be completed to update the lock.

3. To change access rights for a single lock, select lock from the list and:
  - ➔ Press the appropriate single arrow button between the two columns, or
  - ➔ Double click on the lock name.
4. To change access rights for all the listed locks:
  - ➔ Switch one lock at a time (refer to step 3), or





## LOCK / USER EDITOR continued

- ➔ Press the appropriate double arrow button between the two columns.
- ➔ Changing an item on the screen changes only the local computer database. The contents of the lock(s) do not automatically change. The local computer database and a lock's database are two separate and distinct databases. They will not read the same until one is updated to match the other. Refer to **READ/WRITE LOCK** for updating the lock database.

**NOTE:** If there is a change to a user's status, such as supervisor, time based access, passage mode, etc. the box on the right will be unchecked. A Write Changes operation will need to be completed to update the lock.

- ➔ Access rights can also be organized by lock name. If organized by lock name, refer to steps 2-4 but substitute lock access rights for users access rights.

### GROUP EDITOR

The **Group Editor** tab is used to add, edit, or delete groups from the local computer database. This option makes it easier to add or delete users from a group. Users in a group will all have the same time based access to locks.

#### TO ADD A NEW GROUP

1. Select the **Lock/User Editor** window.
  - ➔ If the **Lock/User Editor** window is already open, make sure the **Group Editor** window is open. If not, select the **Group Editor** tab.
2. Select **Add Group** to create a new group in the local computer database.
3. Enter the new group's name.
4. If the new group has no restrictions, check the **No Restrictions** box.
5. If the new group has restricted access to locks, check the days the group is not restricted.
6. Fill in the time slots the new group can access the locks, or check the **All Day** box if the group has 24 hour access.
  - ➔ When filling in time slots, LockView® will automatically wrap a day. (Example: 11 p.m. Monday - 7 a.m. Tuesday.)
7. Select **OK** when done.
8. Select **Close** to close the **Group Editor** tab.

#### TO EDIT A NEW GROUP

1. Select the **Lock/User Editor** window.
  - ➔ If the **Lock/User Editor** window is already open, make sure the **Group Editor** is open. If not select the **Group Editor** tab.
2. Select **Group Name** and then select **Edit Group** to edit the group's restriction information.
3. Select **OK** when done.

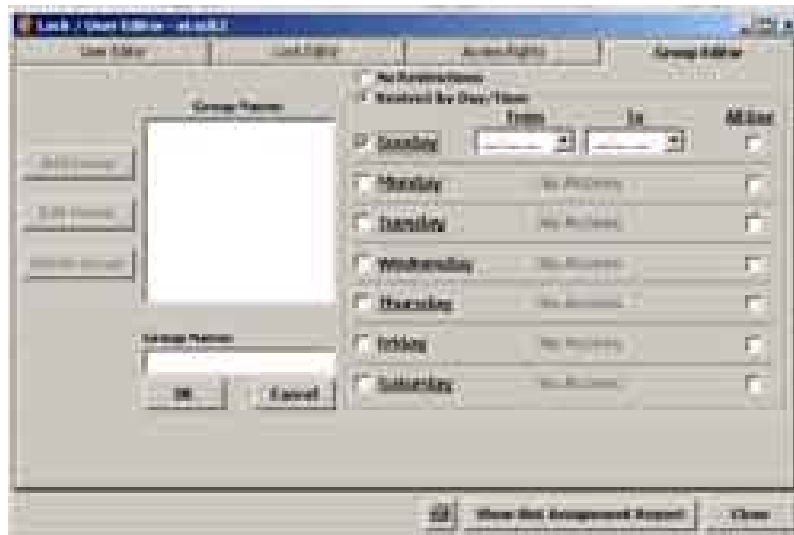

## **LOCK / USER EDITOR continued**

4. Select **Close** to close the **Group Editor** tab.

### **TO DELETE A GROUP**

1. Select the **Lock/User Editor** window.
  - ➔ If the **Lock/User Editor** window is already open, make sure the group editor is open. If not select the **Group Editor** tab.

**NOTE:** *If you delete a restriction group, all users assigned to it will be set to "No Access."*

2. Select **Group Name** and then select **Delete Group** to delete an existing user from the local computer database.
3. Select **Close** to close the **Group Editor** tab.

## READ / WRITE LOCK

The **Read/Write Lock** window contains five (5) tabs that allow the operator to upload the database from a lock and download the audit trail from a lock.

### CONNECTION

The **Connection** tab allows the operator to view the status of the connection and to connect or disconnect to/from a lock. If the icon background is green, it indicates that the USB device and all the drivers are working correctly. **THIS IS NOT AN INDICATION OF WHETHER YOU ARE PHYSICALLY CONNECTED TO THE ELOCK.**



### TO CONNECT TO A LOCK:



1. Select the **Read/Write Lock** window.
    - ➔ If the **Read/Write Lock** window is already open, make sure the **Connection** tab is open. If not, select the **Connection** tab.
  2. Connect the 6 wire RJ11 cable from the lock to the LockView® USB adapter.
  3. Press the **Connect to Lock...** tab.
    - ➔ The quick connect button on the status bar can also be pressed to make a connection to the lock, refer to B2 on page 6.
- If there are problems with the lock connection:
- ➔ Press the **Test Lock** button to test the connection of the cable and lock.

## READ / WRITE LOCK *continued*



### READ SLOTS

The **Read Slots** tab allows the operator to view the slots assigned to users in the database along with the actual contents of the slots in the lock. If the local computer database and the lock contents for a numbered slot do not match, the information in the corresponding slots will be displayed in different colors. The operator will also have the option to update the lock or database per each slot.

A lock must be connected to the computer with the LockView® software to view the **Read Slots** tab.

1. Select the **Read Slots** tab from **Read/Write Lock** window.
2. Connect to a lock. Refer to **CONNECTION**. (previous page)
3. Press the **Read Slots/View Changes To Be Made** button to start the data acquisition and display.



#### LOCK DATABASE INFORMATION

- ➔ User name,
- ➔ Access type,
- ➔ Slot number, and
- ➔ If they have supervisor rights.

#### LOCAL COMPUTER DATABASE INFORMATION

- ➔ User name,
- ➔ Access type,
- ➔ Slot number, and
- ➔ If they have supervisor rights.

This report also shows if information in the slot database of the lock differs from the slot in the local computer database. This is illustrated with blue text, compared to black text. If the entry in the local computer database is in orange, the users information (supervisor status, passage mode status, dual credential status, time based access status) in the database has been modified and will need to be updated within the lock's database.

## READ / WRITE LOCK continued

This Read Slots screen shows:

- ➔ Four slot assignments for the local computer database and a lock titled "CompX eLock"
- ➔ Slots 002, 003, and 004 of the local computer database do not match the lock's database.

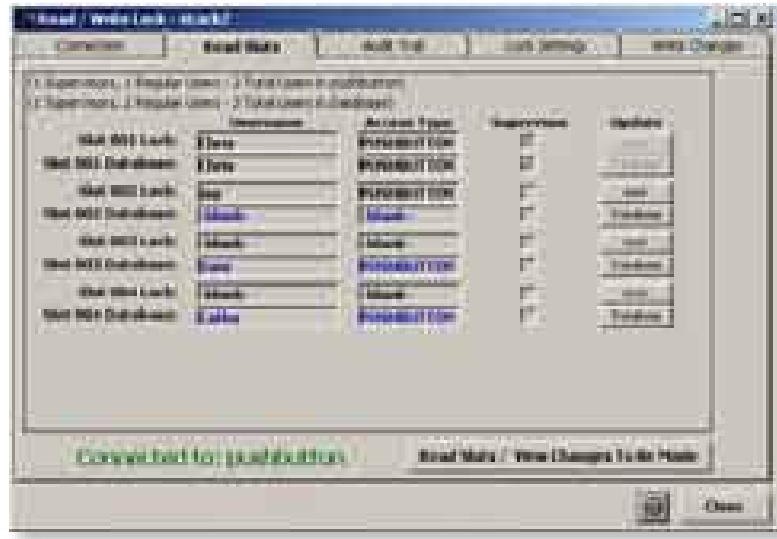

5. The **Update** buttons, on the right side of the tab screen, will allow a direct manipulation of the corresponding slot only.
  - ➔ Press the Lock button to update the lock to match the local computer database, or
  - ➔ Press the Database button to update the local computer database to match the lock.
  - ➔ Once an update button has been pressed for a slot, the contents of that slot in the lock will then match the contents of that numbered slot in the database.

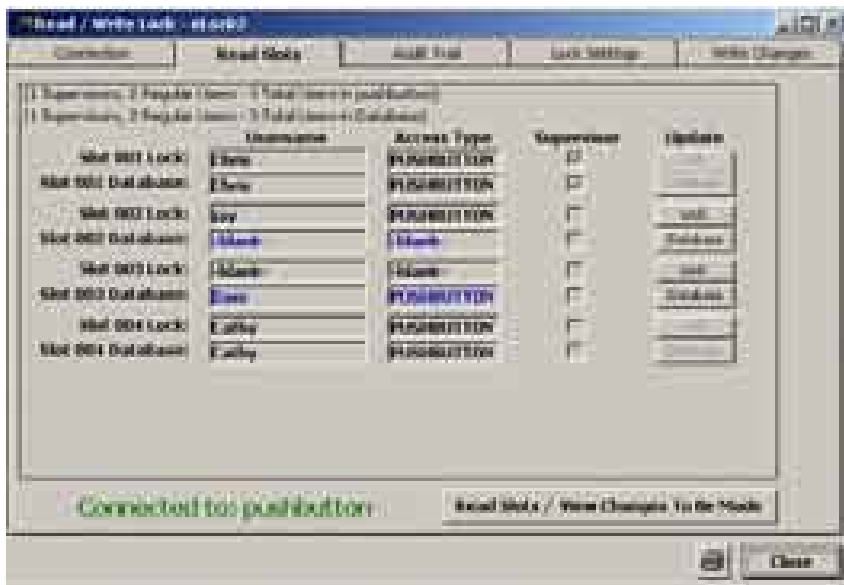

The **Update Lock** button was pressed for slot 004. The local computer database and lock database for slot 004 now matches and user Cathy now has access to the CompX eLock®

The **Update Database** button was pressed for slot 002. The local computer database and lock database for slot 002 now matches and user

## READ / WRITE LOCK continued

Jay is now listed within the local computer's database.

**NOTE:** Go to the Write Changes tab in the Read/Write Lock window to update the entire lock or user database simultaneously.

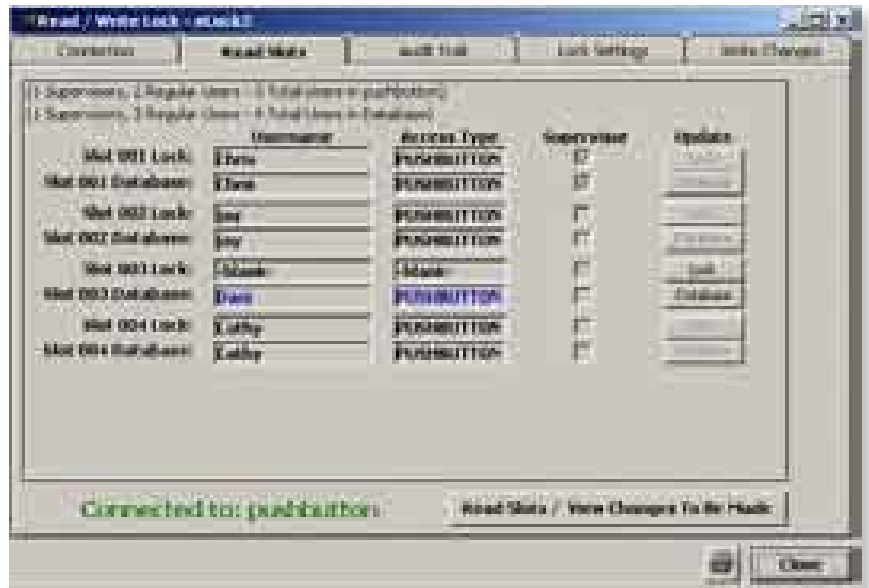

## AUDIT TRAIL

The **Audit Trail** tab allows the operator to view a temperature log (if equipped) or to retrieve the audit trail from the lock to which they are connected. The **View Temp. Log** tab will only appear if LockView is connected and used with a temperature monitoring refrigerator lock. The temperature log allows retrieval and viewing of temperature data. An audit trail is a log of a lock's past operation. These logs include information such as the time and temperature, the name of a user attempting to gain access, name of the lock being accessed, what type of credential is being used, and date and time of attempted access. Temperature logs will display the last 8,000 time / temp recordings. A full audit trail is maximum 1500 entries. The audit trail screen will also allow viewing and manipulation of already retrieved audit trails.

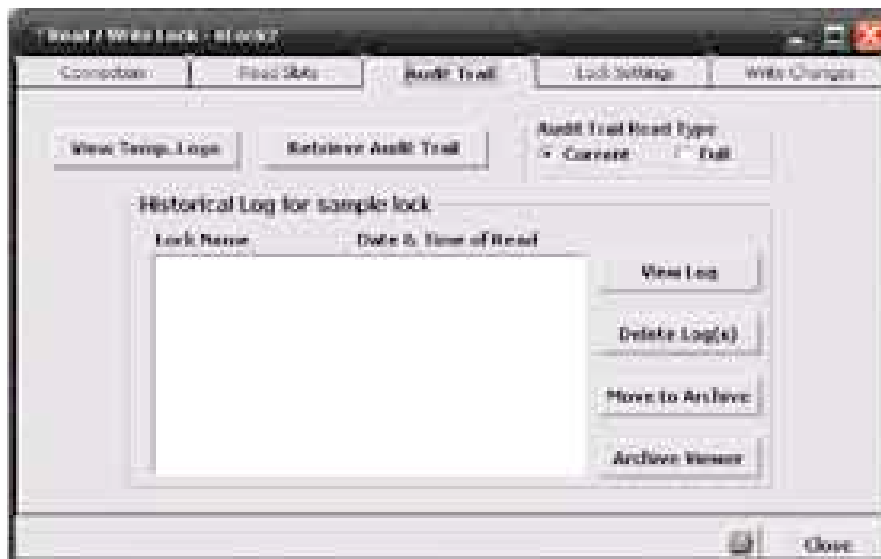

- ➔ A lock must be connected to the computer with the LockView® software to retrieve the audit trail.
- 1. Select the **Audit Trail** tab from **Read/Write Lock** window.
- 2. To connect to a lock, refer to **CONNECTION**.
- 3. Select current or full audit trail type.
  - ➔ Current audit trail will show everything from the last audit trail of the lock until current.
  - ➔ Full audit trail will show every attempted access from the beginning of the lock history (maximum 1500 entries).
- 4. Press **Retrieve Audit Trail** from lock button to start the data acquisition and display.
- 5. The audit trail log for the connected lock displays.



**READ / WRITE LOCK continued****LOG INFORMATION INCLUDES:**

- ➔ Name of the lock being audited
- ➔ Name of the user that attempted access to the lock
- ➔ The credential that was used by the user
- ➔ If the user is a dual credential with "PIN required"
- ➔ If access was granted to the user
- ➔ Date and time of attempted access
- ➔ If access was denied to the user due to time restrictions

To view an older audit trail entry, select a historical audit trail log file and press the **View Log** button.

6. The tool bar at the bottom of the audit trail display allows the operator to close, print, save to an external text file, filter or sort the audit trail log information.

Lock Name	User Name	Type of Access	Status	Date of Entry	Time of Entry
pushbutton	User Not Found	PUSHBUTTON	Access Denied	10/05/08	11:49:04 AM
pushbutton	Chris	PUSHBUTTON	Access Granted	10/05/08	11:49:05 AM
pushbutton	Chris	PUSHBUTTON	Access Granted	10/05/08	11:49:06 AM
pushbutton	Chris	PUSHBUTTON	Access Granted	10/05/08	11:49:08 AM
pushbutton	Chris	PUSHBUTTON	Access Granted	10/05/08	11:49:11 AM
pushbutton	User Not Found	PUSHBUTTON	Access Denied	10/05/08	11:49:52 AM
pushbutton	User Not Found	PUSHBUTTON	Access Denied	10/05/08	11:49:59 AM
pushbutton	My	PUSHBUTTON	Access Granted	10/05/08	11:49:59 AM
pushbutton	My	PUSHBUTTON	Access Granted	10/05/08	11:49:59 AM
pushbutton	My	PUSHBUTTON	Access Granted	10/05/08	11:49:59 AM
pushbutton	Chris	PUSHBUTTON	Access Granted	10/05/08	11:49:40 AM
pushbutton	User Not Found	PUSHBUTTON	Access Denied	10/05/08	11:49:39 AM
pushbutton	User Not Found	PUSHBUTTON	Access Denied	10/05/08	11:49:38 AM
pushbutton	Chris	PUSHBUTTON	Access Granted	10/05/08	11:49:34 AM
pushbutton	Chris	PUSHBUTTON	Access Granted	10/05/08	11:49:32 AM
pushbutton	User Not Found	PUSHBUTTON	Access Denied	10/05/08	11:49:30 AM
pushbutton	User Not Found	PUSHBUTTON	Access Denied	10/05/08	11:49:28 AM
pushbutton	Chris	PUSHBUTTON	Access Granted	10/05/08	11:49:22 AM
pushbutton	User Not Found	PUSHBUTTON	Access Denied	10/05/08	11:49:20 AM
pushbutton	Chris	PUSHBUTTON	Access Granted	10/05/08	11:49:18 AM
pushbutton	User Not Found	PUSHBUTTON	Access Denied	10/05/08	11:49:11 AM
pushbutton	Chris	PUSHBUTTON	Access Granted	10/05/08	11:49:10 AM
pushbutton	User Not Found	PUSHBUTTON	Access Denied	10/05/08	11:49:08 AM
pushbutton	Chris	PUSHBUTTON	Access Granted	10/05/08	11:49:06 AM
pushbutton	Chris	PUSHBUTTON	Access Granted	10/05/08	11:49:04 AM
pushbutton	Chris	PUSHBUTTON	Access Granted	10/05/08	11:49:02 AM
pushbutton	User Not Found	PUSHBUTTON	Access Denied	10/05/08	11:48:59 AM
pushbutton	User Not Found	PUSHBUTTON	Access Denied	10/05/08	11:49:56 AM
pushbutton	Chris	PUSHBUTTON	Access Granted	10/05/08	11:49:26 AM

**THE AUDIT TRAIL LOG CAN BE FILTERED ACCORDING TO:**

- ➔ User Name, or
- ➔ Type of Access.

**THE AUDIT TRAIL LOG CAN BE SORTED ACCORDING TO:**

- ➔ User Name,
- ➔ Type of Access, or
- ➔ Date and Time.

7. After an audit trail has been retrieved, it will reside in the main audit trail tab box along with the date and time of retrieval.
8. Retrieved audit trails can be viewed, deleted and archived by selecting the appropriate button.

**NOTE:** When a lock is connected, the audit trail screen will show the old audit trail logs for that lock only. When NO lock is connected, the audit trail screen will show the old audit trail logs for ALL locks.

## READ / WRITE LOCK continued

### VIEW TEMP LOG

If View Temp Logs is chosen, the eLock's temperature logs will be displayed (see below). The pull down shown at point **A** allows the operator to choose which temperature monitoring eLock's temperature log will be viewed.

After a lock is chosen, the temperature graph is shown in graph area **B**. The corresponding X axis values in the accompanying illustration are shown at point **F** (illustrating the far left time value 7/02/07 2:24pm) and **G** (illustrating the far right time value 7/03/07 2:24pm). The Y axis on this accompanying graph is temperature. The temperature values in Celsius are shown on the left side at **D** and on the right side in Fahrenheit at **E**. The actual graph of temperature vs time is shown at **C**. The time axis can be moved right (earlier in time) or left (later in time) by control buttons **J, K, L and M**. The size (in time) of the overall window can be changed by pull down **H**. The Y axis size can be selected by pull down **I**.

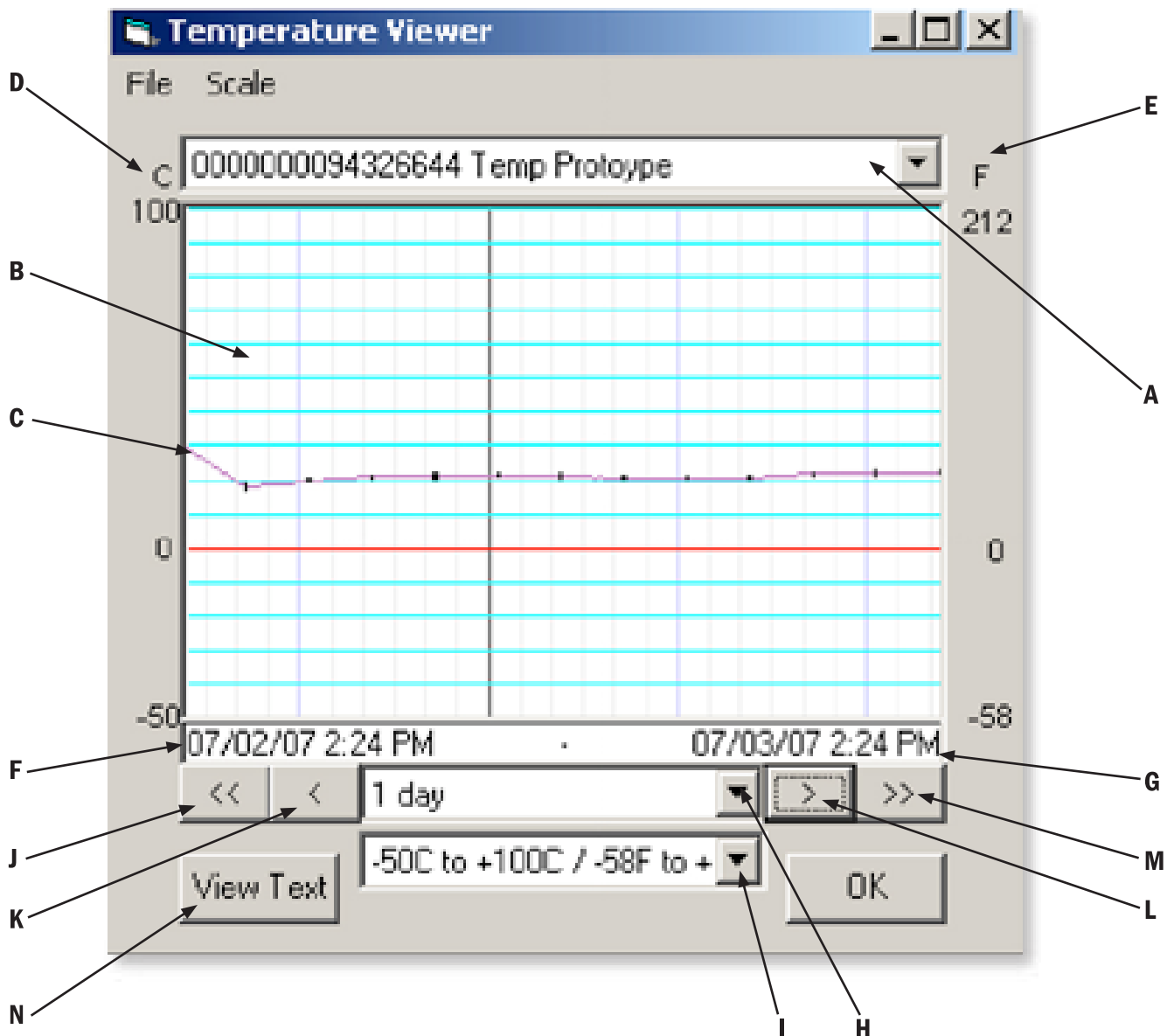

**READ / WRITE LOCK continued**

Finally, the operator can view the actual temperature and time data in text format by pressing button **N** (previous page). Column **O** shows the lock serial number, column **P** shows the event time, column **Q** shows the recorded temperature, column **R** shows the time that the data was retrieved from the lock.

LOCK ID	EVENT ID	EVENT TIME	EVENT DATA	RETRIEVAL TIME
0000000094326644	00233EE8	19/Jun/2007 10:34:04	23.1C 73.6F	19/Jun/2007 11:46:04
0000000094326644	00233EEC	19/Jun/2007 10:34:06	23.1C 73.6F	19/Jun/2007 11:46:04
0000000094326644	00233EF0	19/Jun/2007 10:34:08	23.1C 73.6F	19/Jun/2007 11:46:04
0000000094326644	00233EF4	19/Jun/2007 10:34:10	23.1C 73.6F	19/Jun/2007 11:46:04
0000000094326644	00233EF8	19/Jun/2007 10:34:12	23.1C 73.6F	19/Jun/2007 11:46:04
0000000094326644	00233EFC	19/Jun/2007 10:34:14	23.1C 73.6F	19/Jun/2007 11:46:04
0000000094326644	00233F00	19/Jun/2007 10:34:16	23.1C 73.6F	19/Jun/2007 11:46:04
0000000094326644	00233F04	19/Jun/2007 10:34:18	23.1C 73.6F	19/Jun/2007 11:46:04
0000000094326644	00233F08	19/Jun/2007 10:34:20	23.1C 73.6F	19/Jun/2007 11:46:04
0000000094326644	00233F0C	19/Jun/2007 10:34:22	23.1C 73.6F	19/Jun/2007 11:46:04
0000000094326644	00233F10	19/Jun/2007 10:34:24	23.1C 73.6F	19/Jun/2007 11:46:04
0000000094326644	00233F14	19/Jun/2007 10:34:26	23.1C 73.6F	19/Jun/2007 11:46:04
0000000094326644	00233F18	19/Jun/2007 10:34:28	23.1C 73.6F	19/Jun/2007 11:46:04
0000000094326644	00233F1C	19/Jun/2007 10:34:30	23.1C 73.6F	19/Jun/2007 11:46:04
0000000094326644	00233F20	19/Jun/2007 10:34:32	23.1C 73.6F	19/Jun/2007 11:46:04
0000000094326644	00233F24	19/Jun/2007 10:34:34	23.1C 73.6F	19/Jun/2007 11:46:04
0000000094326644	00233F28	19/Jun/2007 10:34:36	23.1C 73.6F	19/Jun/2007 11:46:04
0000000094326644	00233F2C	19/Jun/2007 10:34:38	23.1C 73.6F	19/Jun/2007 11:46:04
0000000094326644	00233F30	19/Jun/2007 10:34:40	23.1C 73.6F	19/Jun/2007 11:46:04
0000000094326644	00233F34	19/Jun/2007 10:34:42	23.1C 73.6F	19/Jun/2007 11:46:04
0000000094326644	00233F38	19/Jun/2007 10:34:44	23.1C 73.6F	19/Jun/2007 11:46:04
0000000094326644	00233F3C	19/Jun/2007 10:34:46	23.1C 73.6F	19/Jun/2007 11:46:04
0000000094326644	00233F40	19/Jun/2007 10:34:48	23.1C 73.6F	19/Jun/2007 11:46:04
0000000094326644	00233F44	19/Jun/2007 10:34:50	23.1C 73.6F	19/Jun/2007 11:46:04
0000000094326644	00233F48	19/Jun/2007 10:34:52	23.1C 73.6F	19/Jun/2007 11:46:04
0000000094326644	00233F4C	19/Jun/2007 10:34:54	23.1C 73.6F	19/Jun/2007 11:46:04
0000000094326644	00233F50	19/Jun/2007 10:34:56	23.1C 73.6F	19/Jun/2007 11:46:04
0000000094326644	00233F54	19/Jun/2007 10:34:58	23.1C 73.6F	19/Jun/2007 11:46:04
0000000094326644	00233F58	19/Jun/2007 10:35:00	23.1C 73.6F	19/Jun/2007 11:46:04

## READ / WRITE LOCK continued

### LOCK SETTINGS

The **Lock Settings** tab allows the operator to view the operating characteristics and parameters of the lock to which they are connected. The internal time of the lock and the computer are displayed on this screen. If the time differs, the operator has the option of updating the lock to match the computer.

A lock must be connected to the computer with the LockView® software to view the operating characteristics of the lock.

1. Select the **Lock Settings** tab from **Read/Write Lock** window.
2. Connect to a lock. Refer to **CONNECTION**.
3. The lock and local computer database characteristics and parameters display.

This screen shows:

- ➔ Lock access type
- ➔ Passage mode
- ➔ Lock Voltage
- ➔ Lock type
- ➔ No PIN required
- ➔ Bad Credential Lockout
- ➔ Open time



This report also shows if information in the lock database differs from the information in the local computer database. This is illustrated with blue text, compared to black text.

- ➔ The lock parameter information can be found and/or edited by opening the **Lock Editor** tab.
4. Press the **Refresh** button to compare lock data to local computer database data.
  5. The **Update Lock Button** at the bottom of the **Lock Settings** screen will allow a direct manipulation of the lock database.
    - ➔ Press the **Update Lock** button to update the lock to match the local computer database.
  6. Press the **Set lock's date and time to current system date and time** and time.
    - ➔ The lock will automatically update daylight savings time in the spring and fall if the computer it is connected to is set to automatically update.
    - ➔ To check this setting, double click the clock in the bottom right of the computer's start bar, then click on "Time Zone." There is a box there for automatic daylight savings time.

**NOTE:** If "N/A" appears in the "Lockout" area, the connected eLock is version 2.0; the variable lockout feature is not available on eLocks v2.0.

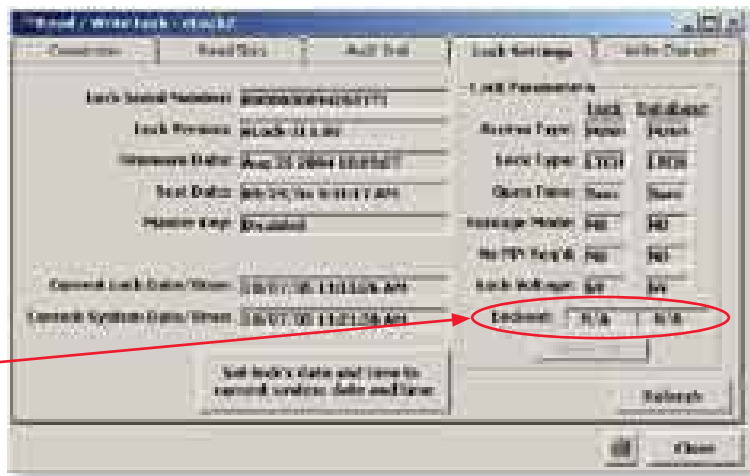

### E3 TEMPERATURE MONITORING (IF EQUIPPED)

If the lock has temperature monitoring capabilities, a button labeled **E3** appears next to the update lock button on the **Read/Write Lock** screen. Selecting this button displays the **eLock 3 Options** screen. The eLock 3 Options screen shown on page 27 is divided into three sections called **User Permissions**, **Temperature/Alarm Settings**, and **Logging Frequency**.

## READ / WRITE LOCK continued

The upper section **(W) (User Permissions)** is used to select which manual programming temperature monitoring options can be accessed by Supervisors and Users. The first column of check boxes **(A)** shows which options are available to Users; the second column **(B)** shows which options are available to Supervisors. The presence of a check mark denotes which Supervisors or Users can use the corresponding option.

The following options are available:

### Reset min/max observations **(C)**

This option allows Supervisors/Users to access the R'SET (reset) option within the manual temperature programming screens. The temperature monitoring CompX eLock® has the ability to show the maximum and minimum temperatures that the electronics observed since the last time the MIN/MAX observations screens were reset. These observations can be viewed by pressing the up and down buttons on the temperature monitoring keypad. If it is desired to reset these observations to the currently observed temperature, Users and Supervisors can access the R'Set screen. This setting mode allows the operator to control if Users (in addition to Supervisors) have the ability to reset these observations. It is not possible to remove the ability for Supervisors to reset these observations.

### Set upper and lower alarm limits **(D)**

This option allows Supervisors/Users to set the high temperature and low temperature alarming points within the manual temperature programming screens. The temperature monitoring CompX eLock® has the ability to sound an alarm if the temperature that the electronics observes goes over the maximum temperature set point or under the minimum temperature set point. These set points can be modified within the manual temperature programming screens. This setting mode allows the operator to control if Users (in addition to Supervisors) have the ability to modify these set points. It is not possible to remove the ability for Supervisors to change these set points.

**Mute the alarm **(E)**** This option allows Supervisors/Users to mute an alarm that is sounding for 6 minutes. If this alarm needs to be muted, this can be done with the manual temperature programming screens. It is not possible to remove the ability for Supervisors to mute the alarm.

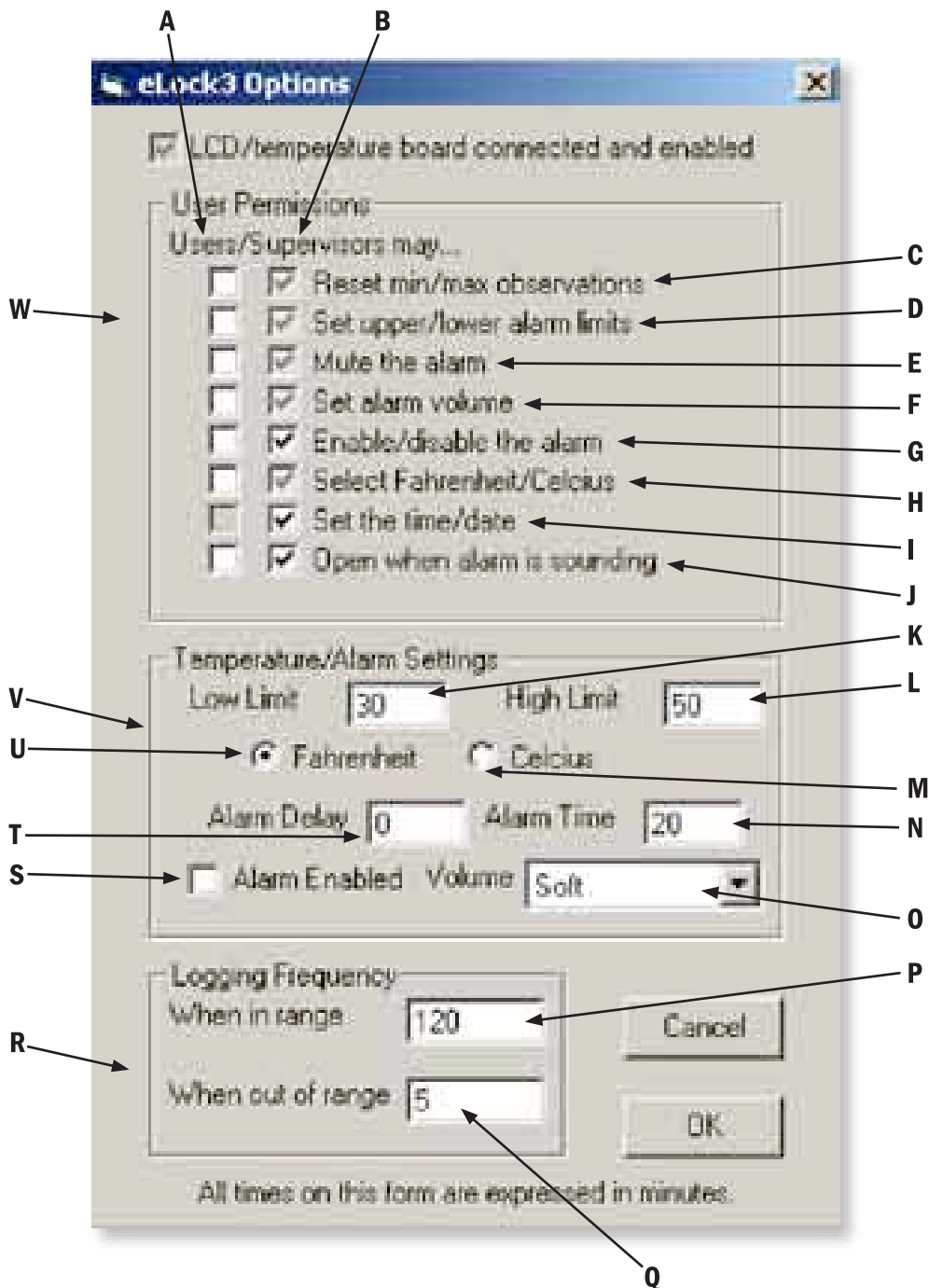

**READ / WRITE LOCK continued**

**Set the alarm volume (F)** This option allows Supervisors/Users to set the alarm volume within the manual temperature programming screens. If the temperature that the electronics observes exceeds the maximum set point or is under the minimum temperature set point, the alarm will sound. This alarm can have one of three different volume levels: **Loud, Medium or Soft**. If the volume needs to be changed this can be done with the manual temperature programming screens. This setting mode allows the operator to control if Users (in addition to Supervisors) have the ability to change the alarm volume. It is not possible to remove the ability for Supervisors to change the alarm volume.

**Enable/disable the alarm (G)** This option allows Supervisors/Users to turn on the high temperature and low temperature alarm within the manual temperature programming screens. The temperature monitoring CompX eLock® has the ability to sound an alarm if the temperature that the electronics observes goes over the maximum temperature set point or under the minimum temperature set point. This alarm feature can be enabled or disabled within the manual temperature programming screens. This setting mode allows the operator to control if Supervisors/Users have the ability to enable or disable the alarm. If neither Supervisors nor Users have the ability to enable or disable the alarm, the only way to do this is through LockView®.

**Select Fahrenheit/Celsius (H)** This option allows Supervisors/Users to choose the unit of measure that the CompX eLock® will display within the manual temperature programming screens. This setting mode allows the operator to control if Users (in addition to Supervisors) have the ability to change the units of measure. It is not possible to remove the ability for Supervisors to change the units of measure.

**Set the date/time (I)** This option allows Supervisors/Users to set the date and time within the manual temperature programming screens. This setting mode allows the operator to control if Users (in addition to Supervisors) have the ability to change the date and time. If neither Supervisors nor Users have the ability to set the time, the only way to do this is through LockView®.

**Open when alarm is sounding (J)** This option allows Supervisors/Users to access (open) the CompX eLock® when the alarm is sounding. If the box is checked, Users/Supervisors will have the ability to unlock the lock when the CompX eLock® is alarming. If the Supervisor button is not checked, Supervisors will have to mute the alarm before accessing the lock, preventing inadvertent use of a product that has been exposed to temperatures outside of the set alarm temperatures ranges.

The middle section **(V) (Temperature/Alarm Settings)** is used to enable and set the temperature alarm. Checking the **Alarm Enabled** check box **(S)** enables the temperature alarm. It will have a High Limit **(L)** corresponding to the setting in the High Limit entry area, a Low Limit **(K)** corresponding to the setting in the Low Limit entry area, the units of measure will be either Fahrenheit **(U)** or Celsius **(M)** and the volume of the alarm **(O)** will correspond to the volume chosen in the Volume pull down.

The **Alarm Delay section (T)** allows the operator to choose how much time (in minutes) the electronics will observe a temperature above the high limit or below the low limit before sounding the alarm.

The **Alarm Time section (N)** allows the operator to choose how long the alarm will sound (in minutes) after the alarm begins to sound. Once the set amount of time has passed, the CompX eLock® will chirp one time per minute until alarm has been disabled or muted.

The lower section **(R) (Logging Frequency)** is used to set how often the CompX eLock® will log the temperature. If the temperature that the CompX eLock® observes is above the low limit setting and below the high limit setting, the temperature will be logged at the rate (in minutes) that is in the **When in range (P)** entry area. If the temperature that the CompX eLock® observes is below the low limit setting or above the high limit setting, the temperature will be logged at the rate (in minutes) that is in the **When out of range (Q)** entry area.

Clicking **OK** will save the settings to the CompX eLock® 3.



## READ / WRITE LOCK continued

### WRITE CHANGES

The **Write Changes** tab allows the operator to update the entire lock or local computer database simultaneously. A lock must be connected to the computer with the LockView® software to update the lock or local computer database.

1. Select the **Write Changes** tab from **Read/Write Lock** window.
2. Connect to a lock, refer to **CONNECTION**.
3. Press the **Determine Changes** button to start the update process.
4. After the changes have been determined, the number of changes are noted.
5. Press the **Update Lock from Database** button to update the contents of the slots in the lock to match the local computer's database slot information. Press the **Update Database from Lock** button to update the contents of the slots in the local computer database to match the lock's slot information.

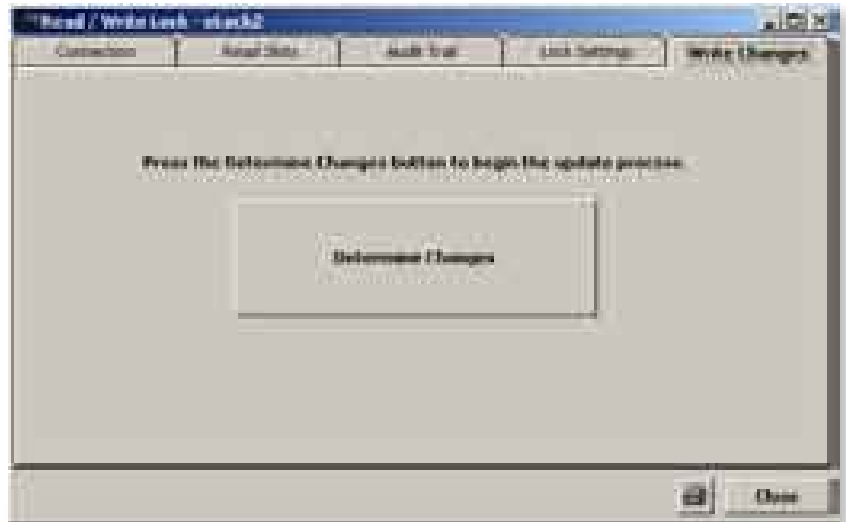

- ➔ Pressing one of these update buttons will make all of the changes to the lock or local computer database. If the operator is unsure of all the changes to be made, refer to the **Read Slots** tab to fully illustrate the changes.

**NOTE:** Go to the **Read Slots** tab in the **Read/Write Lock** window to update a single slot in the lock or local computer database at a time.

### PROGRAMMING EXAMPLE

Follow this example as two new users are added into the local computer database and then added into a lock's database.

1. Select the **Lock/User Editor** window.
2. Select **Add User** and type in new user's information.

**NOTE:** Screens below are of new users being added to the local computer database.

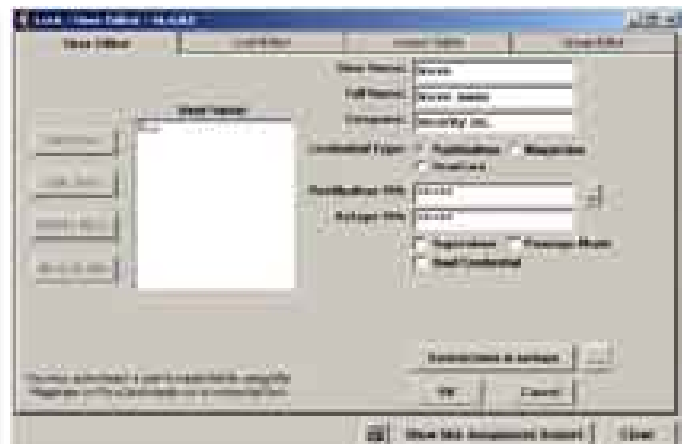
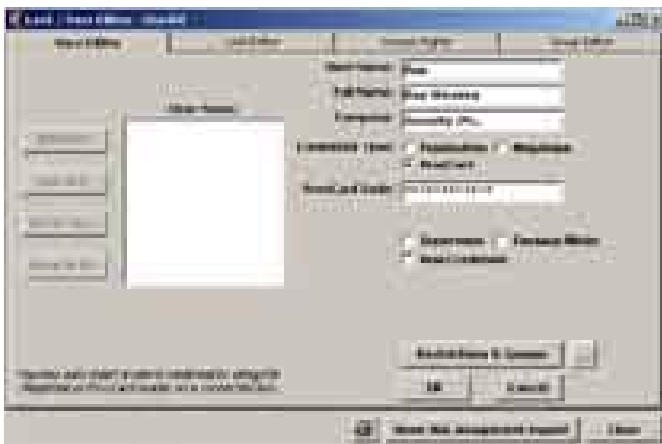

## READ / WRITE LOCK continued

User information for Ron and Steve is added into the local computer database by using the User Editor.

The new users do not have any access rights to locks, or cannot open locks, within the LockView® program, yet.

3. Open the Lock Editor tab
4. Select Add Lock.

**NOTE:** The screen below is of a new lock being added to the local computer database.

Lock information for CompX eLock® is added into the local computer database by using the Lock Editor.

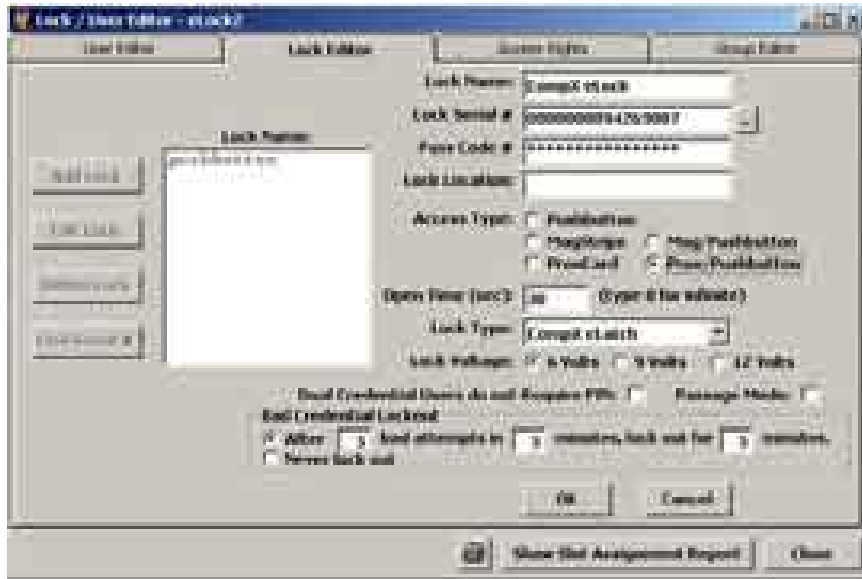

5. Open the Access Rights tab.

The screen below shows users Ron and Steve DO NOT have access to the CompX eLock®



## READ / WRITE LOCK continued

By highlighting Ron and Steve and selecting the appropriate arrow, these two new users are granted access to the CompX eLock® as it shows in the bottom screen (which is the contents of the local computer's database), but they still are not able to open the lock until they are uploaded into the lock's database. The two new users will not have a check mark next to their names and will not be able to open the CompX eLock® until they are uploaded into the lock's database. When they are uploaded, a check mark will appear in the box next to their names in the right column.

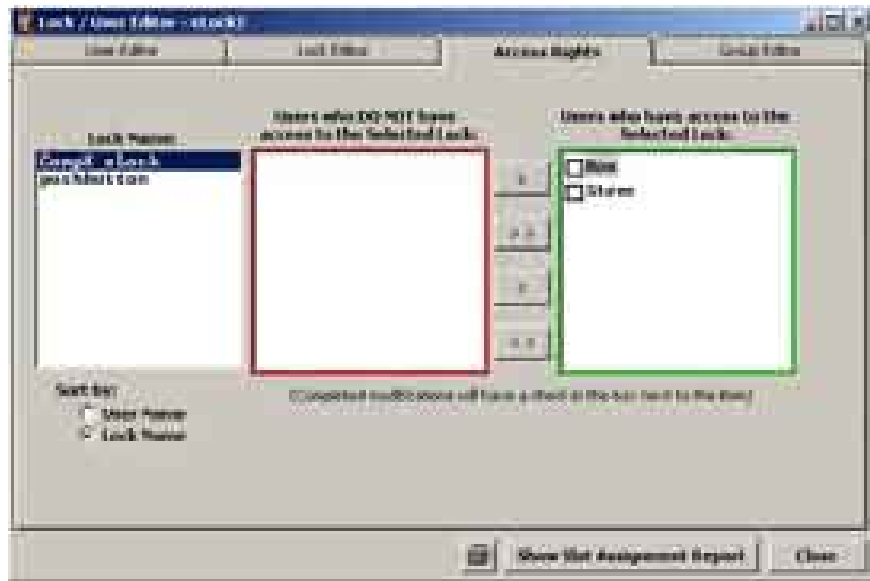

6. Connect to the CompX eLock®
7. Select the Read/Write Lock window.
8. Select the Read Slots tab and press the Read Slots/View Changes To Be Made button.



## READ / WRITE LOCK *continued*

This **Read Slots** screen shows the new users Ron and Steve in the local computer's database in slots 001 and 002, but not in the CompX eLock® database. From the **Read Slots** screen, single slots in the lock or the local computer's database can be updated to read the same.

9. Press the **Update Lock** button for slot 001.



*New user Ron is now updated in the CompX eLock® and the lock will now open for him.*

*In the Read Slots screen, slots within the local computer database or within the lock can be updated one slot at a time. If the entire database for the local computer or the lock needs to be updated, this can be done in the Write Changes screen.*

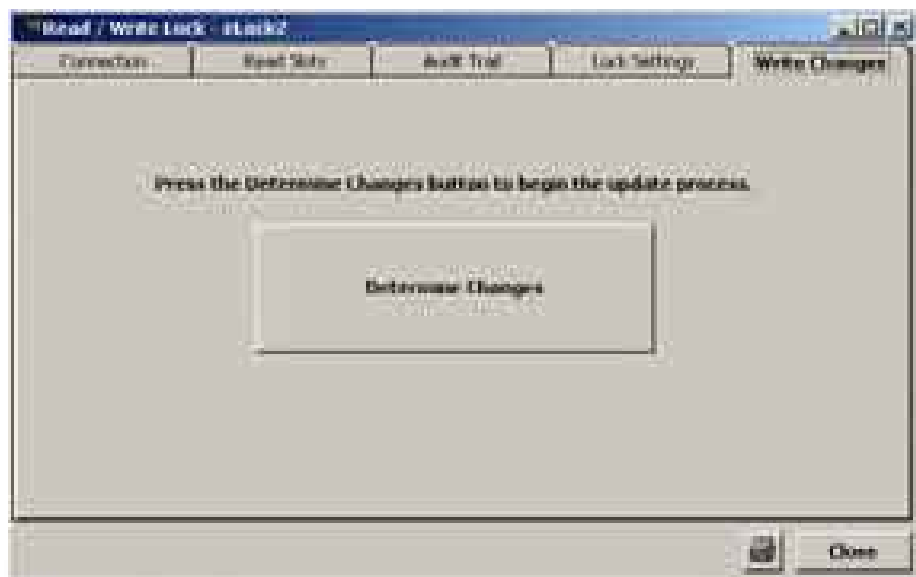

10. Select the **Write Changes** tab and press the **Determine Changes** button.

## READ / WRITE LOCK *continued*

When the **Determine Changes** button is pressed, the local computer database and the lock database are compared for differences.



In this case, the system found one update to be made. If the **Update Lock from Database** button is pressed, all the needed updates, or non-matching slots, in the lock will be updated to match the slots in the local computer's database.

If the **Update Database from Lock** button is pressed, all the needed updates, or non-matching slots, in the local computer's database will be updated to match the slots in the lock.

Press the **Update Lock from Database** button to make the one update the system found to the lock's database.

Open the **Read Slots** screen and press the **Read Slots/View Changes to be Made** button to review the changes made to either the local computer's database or the lock's database.

The **Read Slots** screen now shows all corresponding slot numbers containing matching information.



## READ / WRITE LOCK continued



The Access Rights screen now shows check marks next to new users Ron and Steve.

## GLOSSARY OF TERMS

**ACCESS RIGHTS** – Ability for a user to open a lock.

**AUDIT TRAIL** – A log of a lock's past operation.

**ARCHIVE** – To save into history.

**COM PORT** – Serial port on computer used to connect to a lock.

**CREDENTIAL** – PIN, magstripe, or prox card used to open a lock.

**DATE FORMAT** – Date can be viewed as month/day/year or day/month/year and is selectable in the LockView® Options window.

**DUAL CREDENTIAL** – After a user's primary credential is shown a secondary PIN credential must be shown to gain access to the lock.

**FILTER BY** – To view according to selection.

**HID PROX CARDS** – HID manufactures the system of prox cards that the CompX eLock® uses. They have 4 pieces of important data. The format is the number of bits that the card has encoded on it. Typically this is 26,34,35, or 37 bits. Each format is set up slightly differently, however most have a facility code and card number. Typically each installation site has a common facility code and unique card numbers. This information can be directly enters using the PROX card entry window in the user editor.

**HIGH TEMPERATURE LIMIT** – The maximum allowable temperature that the CompX eLock® equipped with temperature monitoring can observe before sounding the Temperature alarm

**LOCAL COMPUTER DATABASE** – The collection of data within the software.

**LOCK EDITOR** – Used to add, edit, or delete locks from the software database.

**LOCK SERIAL NUMBER** – Identification number.

**LOCK SLOT DATA** – Information contained within a lock slot.

**LOW TEMPERATURE LIMIT** – The minimum allowable temperature that the CompX eLock® equipped with temperature monitoring can observe before sounding the temperature alarm

**MAGSTRIPE** – Lock access credential.

**ODBC** – Pointer to your database on the local computer.

**OPERATOR** – Person with access to the LockView® software.

**OPERATOR EDITOR** – Used to add, edit, or delete operators from the LockView® software.

**PASS CODE NUMBER** – If the local computer does not have the correct pass code for the lock, the lock will not allow access. This is used for prevention of unauthorized use.

**PASSAGE MODE** – The lock will change it's state (lock/unlock) after the this user's credential has been shown.

**PROX CARD** – Lock access credential.

**PUSHBUTTON PIN** – Lock access credential.

**READ/WRITE LOCK** – Menu used to connect to, read, or update a lock.

**RECYCLE BIN** – Garbage receptacle for deleted users. Deleted users must be emptied from the Recycle Bin to be completely deleted from the program.

**RESTRICTIONS & GROUPS** – Day and time restrictions to access a lock.

**SERIAL ADAPTER** – Adapter found between the serial port and the lock's communication cable.

**SERIAL PORT** – Found on a computer and used to transfer information via serial cable.



## **GLOSSARY OF TERMS continued**

**SLOT ASSIGNMENT REPORT** – A listing of all users with access to a lock(s).

**SLOTS** – A lock's internal memory is divided into 250 slots that store users information. Each slot can hold a user or supervisor.

**SOFTWARE DATABASE** – The collection of information within the LockView® software.

**SORT BY** – To arrange according to user name, type of access, or date and time.

**SUPERVISOR RIGHTS** – Access granted to a user to program locks without the LockView® software.

**SYNCHRONIZE** – To make the information between the LockView® software and a lock the same.

**TEMPERATURE ALARMING** – The CompX eLock® equipped with temperature monitoring has the ability to alarm if the observed temperature is below a programmable low limit or above a programmable high limit.

**TEMPERATURE LOGGING** – The ability to record the temperature observed by the CompX eLock® equipped with the temperature monitoring system. These observed temperatures can be downloaded and viewed in the audit trail screen. The frequency (in minutes) is selectable.

**TEMPERATURE MONITORING** – The ability to report the current temperature of the environment that the temperature probe is installed in.

**TEMPERATURE PROBE** – Device that converts temperature into a usable electrical resistance that can be read by the CompX eLock® equipped with the temperature monitoring system.

**USB DONGLE** – Device that plugs into the USB port to facilitate communication between the PC and the CompX eLock.

**USER DATABASE** – The collection of data within the software.

**USER EDITOR** – Used to add, edit, or delete users from the software database.

**USER OR REGULAR USER** – Person with access to one or more locks.

**WIRED AUDIT TRAIL** – A means of gathering the audit trail through the telephone cable while directly connected to the lock.

# COMPX ELOCK® ACCESSORIES



## AC ADAPTER

Part Numbers:  
**EL-2004-9VWB**  
(for use with the CompX eLock® kit)  
**EL-2004-ACWB**  
(for use with 12V electric strikes)



## LATCH SPLITTER

(for running up to 2 latches)  
Part Number:  
**EL-2004-LS**



## LATCH CABLE,\* 24"

Part Number:  
**EL-2004-LC**



## MOTORIZED LATCH\*

Part Number:  
**EL-LATCH-3**



## HID® PROX USER, SUPERVISOR CARD

Part Number:  
**EL-2004-PC** (no logo)  
**EL-2004-PC-S** (CSP logo)



## MOTORIZED LATCH\*

Part Number:  
**EL-2004-ML**



## LOCK VIEW® SOFTWARE KIT

(provided with 7ft., 6-pin RJ11 cable,  
1-USB dongle, 1 LockView CD)

Part Number:  
**EL-2004-LV**



## RJ 11 EXTENSION KIT, 4"

Part Number:  
**EL-2004-RJ KIT**



## HID® PROX TAG

Part Number:  
**EL-2004-PT**



## MAGSTRIPE USER, SUPERVISOR CARD

Part Number:  
**EL-2004-MS** (no logo)  
**EL-2004-MS-S** (CSP logo)

# ELOCK CUTOUT TEMPLATE

Use the diagrams below as a template for holes to be drilled and for mounting your CompX eLock®. Put this template on the **OUTSIDE** of the cabinet door where the eLock will go, and drill the mounting holes for the CompX eLock®.

**1"**  
**NOTE:**  
 Print this page and measure the line above. It is **ONE INCH LONG**. If it measures less than or more than one inch, the template measurements also need to be scaled accordingly.

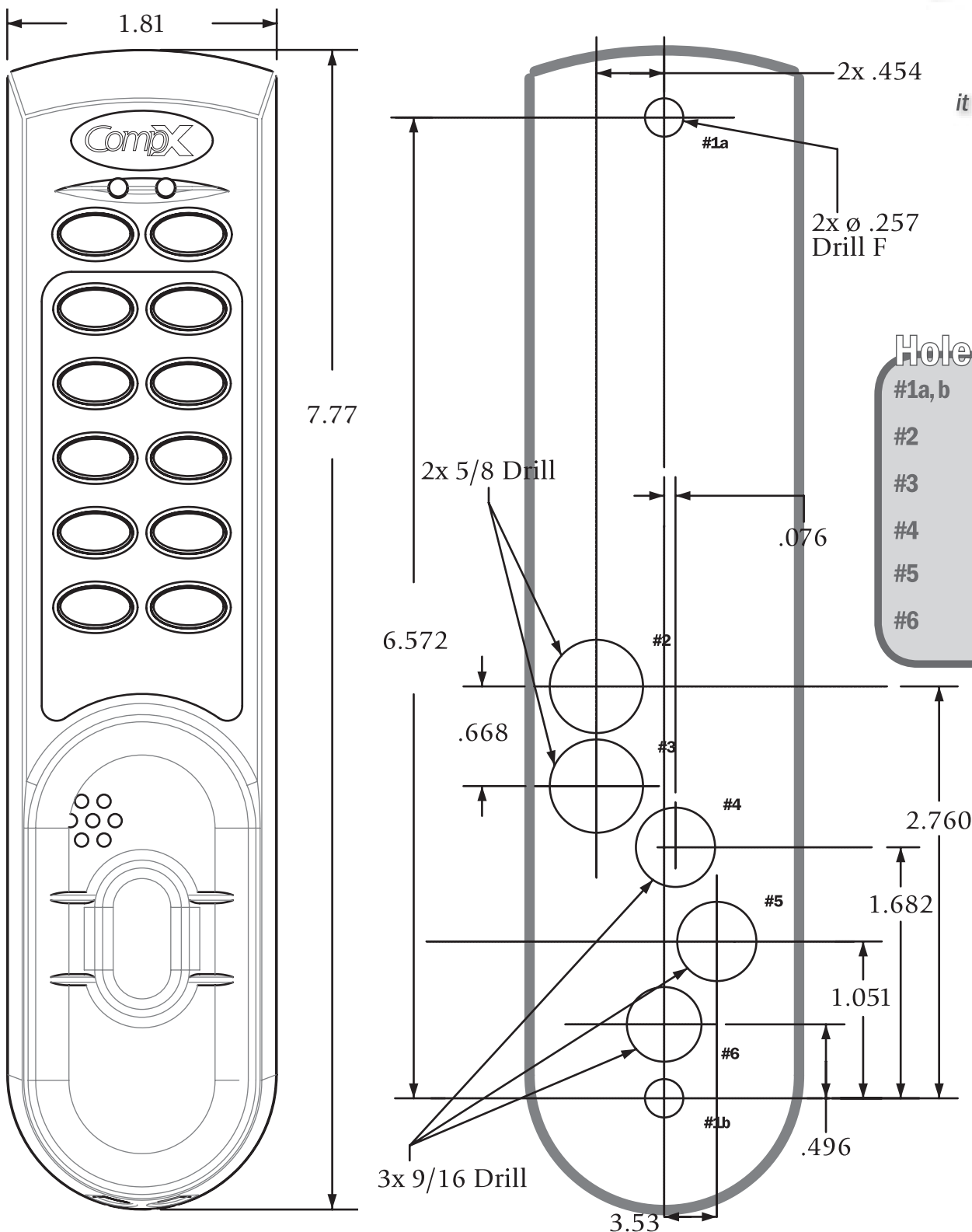

Hole Function	
#1a, b	Mounting Holes required
#2	Battery Latch Cable required
#3	Alarm optional
#4	Battery Cable* optional
#5	RJ11 Port required only if using LockView
#6	AC Wall Adapter* optional

\* If you're using a battery cable, then a wall adapter is not required. If you're using a wall adapter, then battery cable is not required.

Recommended Cabinet Cutout Pattern

## LATCH CUTOUT TEMPLATE

Use the diagrams below as a template for holes to be drilled and for mounting your CompX eLock® latch. Put this template on the inside of the cabinet door where the latch will go, and drill the mounting holes for the CompX eLock® latch.

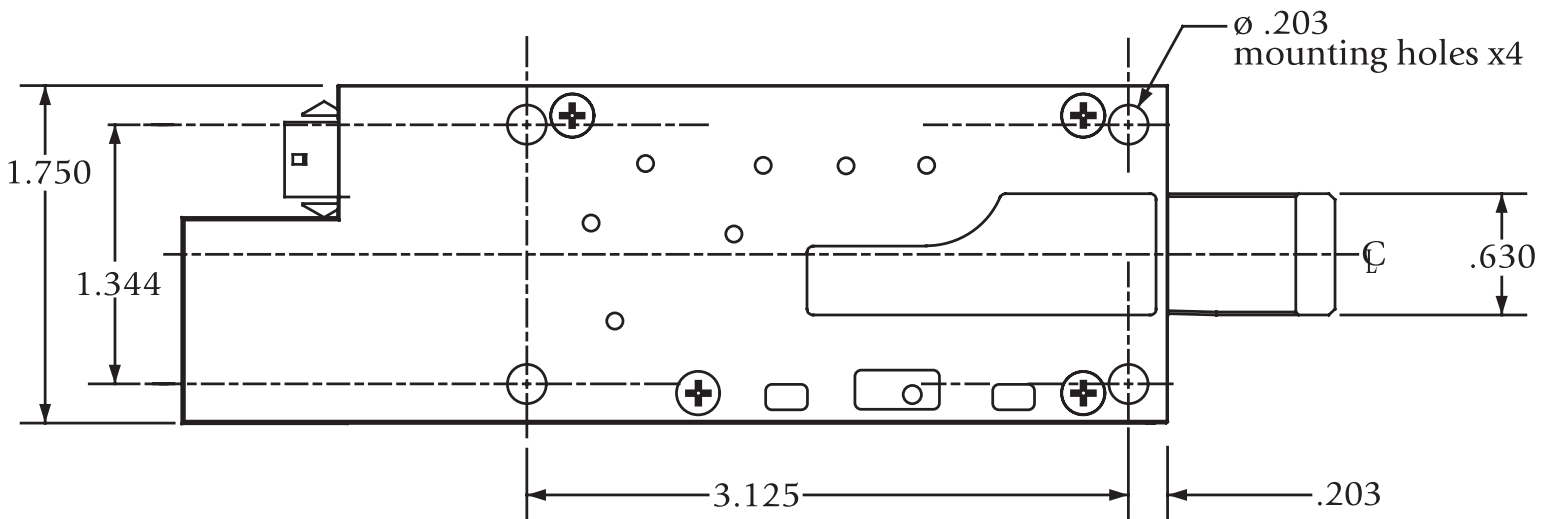
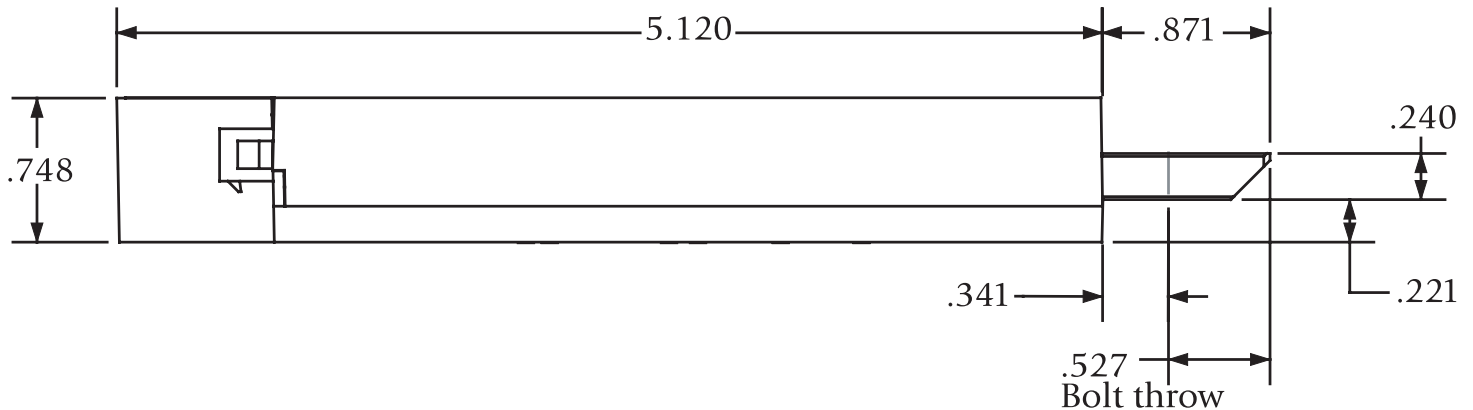

SCALE 1:1



### **WARNING:** ——— 1"

Print this page and measure the line above. It is **ONE INCH LONG**. If it measures less than or more than one inch, the template measurements also need to be scaled accordingly.

**FAILURE TO DO SO COULD RESULT IN MISDRILLED HOLES.**

# DEAD BOLT LATCH (FRACTIONAL DIMENSIONS)



**NOTE:** \_\_\_\_\_ 1"

**NOT ACTUAL SIZE!**  
 Print this page and measure the line above. It is **ONE INCH LONG**. If it measures less than or more than one inch, the template measurements also need to be scaled accordingly.

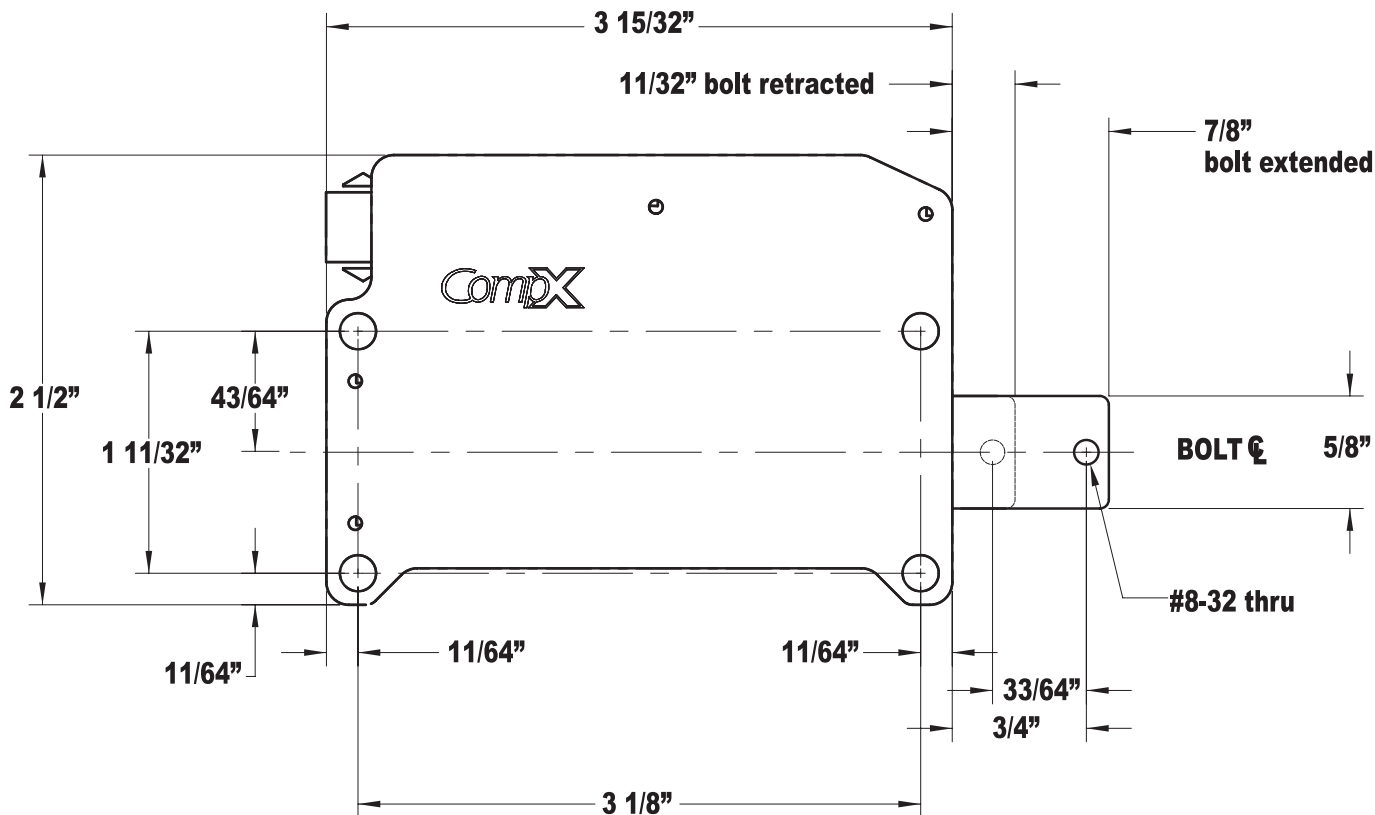
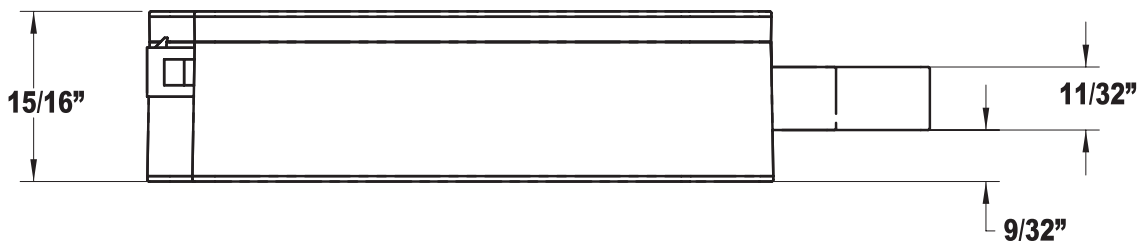
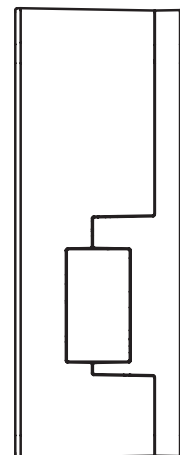
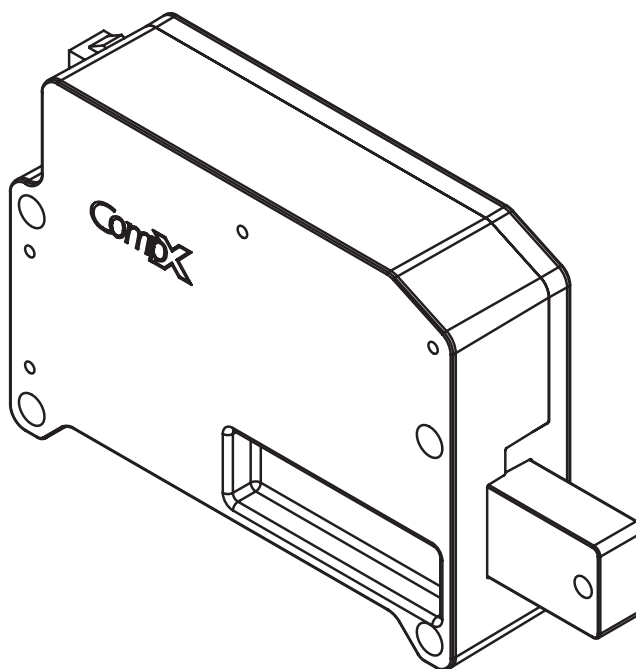

# DEAD BOLT LATCH (DECIMAL DIMENSIONS)



**NOTE:** \_\_\_\_\_ 1"

**NOT ACTUAL SIZE!**  
 Print this page and measure the line above. It is **ONE INCH LONG**. If it measures less than or more than one inch, the template measurements also need to be scaled accordingly.

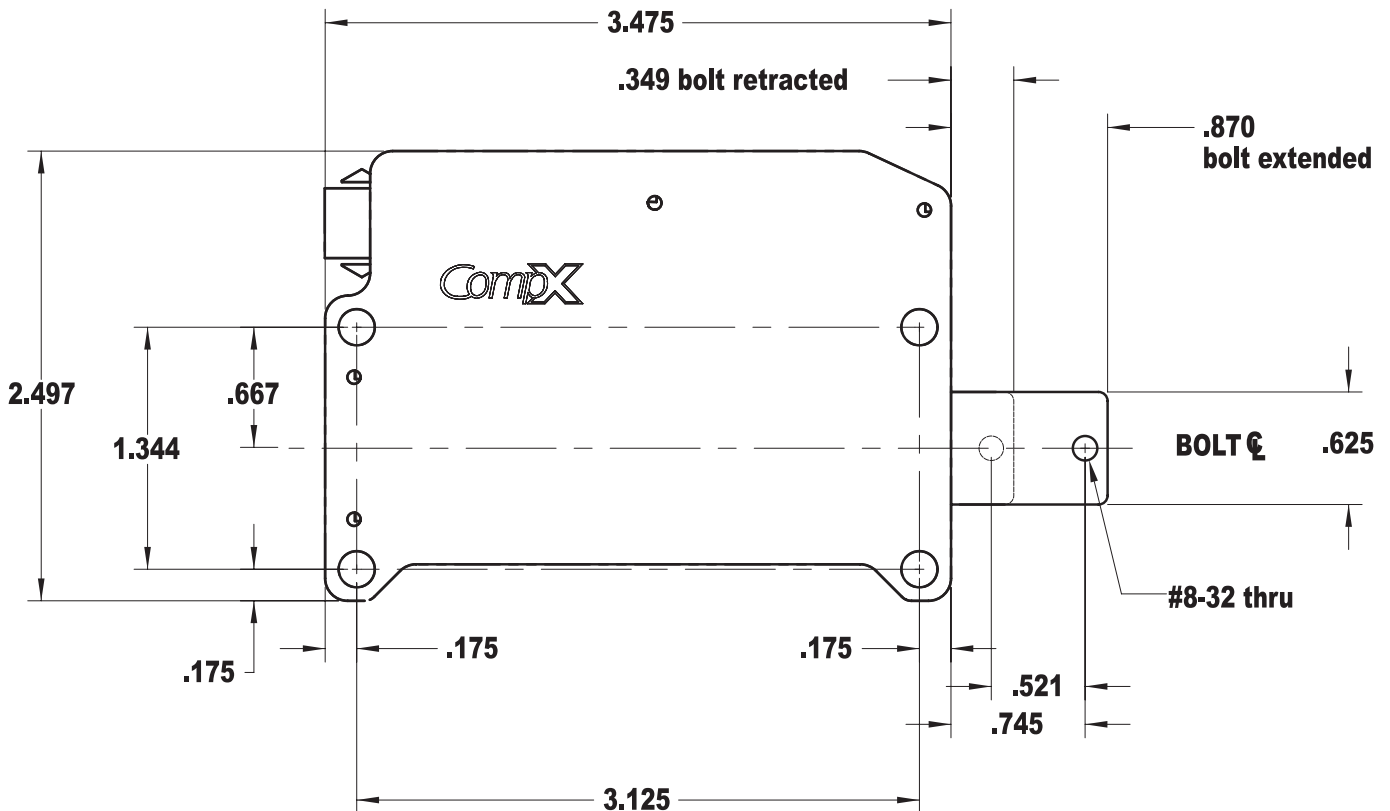
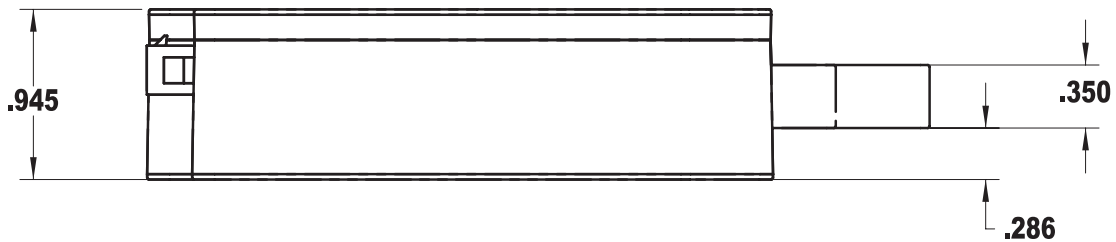
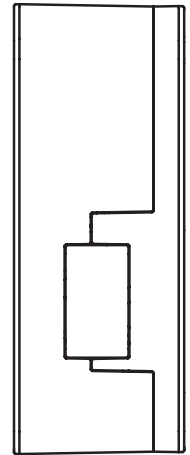
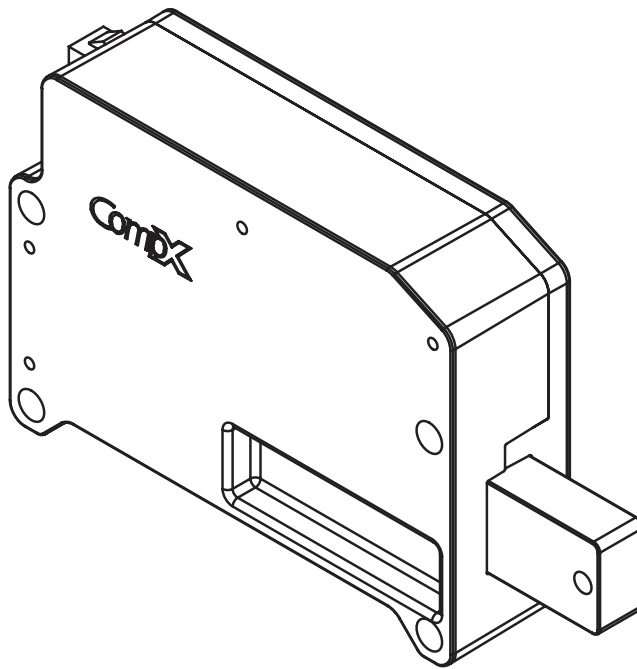

# SLAM BOLT LATCH (FRACTIONAL DIMENSIONS)



**NOTE:**  1"

**NOT ACTUAL SIZE!**  
 Print this page and measure the line above. It is **ONE INCH LONG**. If it measures less than or more than one inch, the template measurements also need to be scaled accordingly.

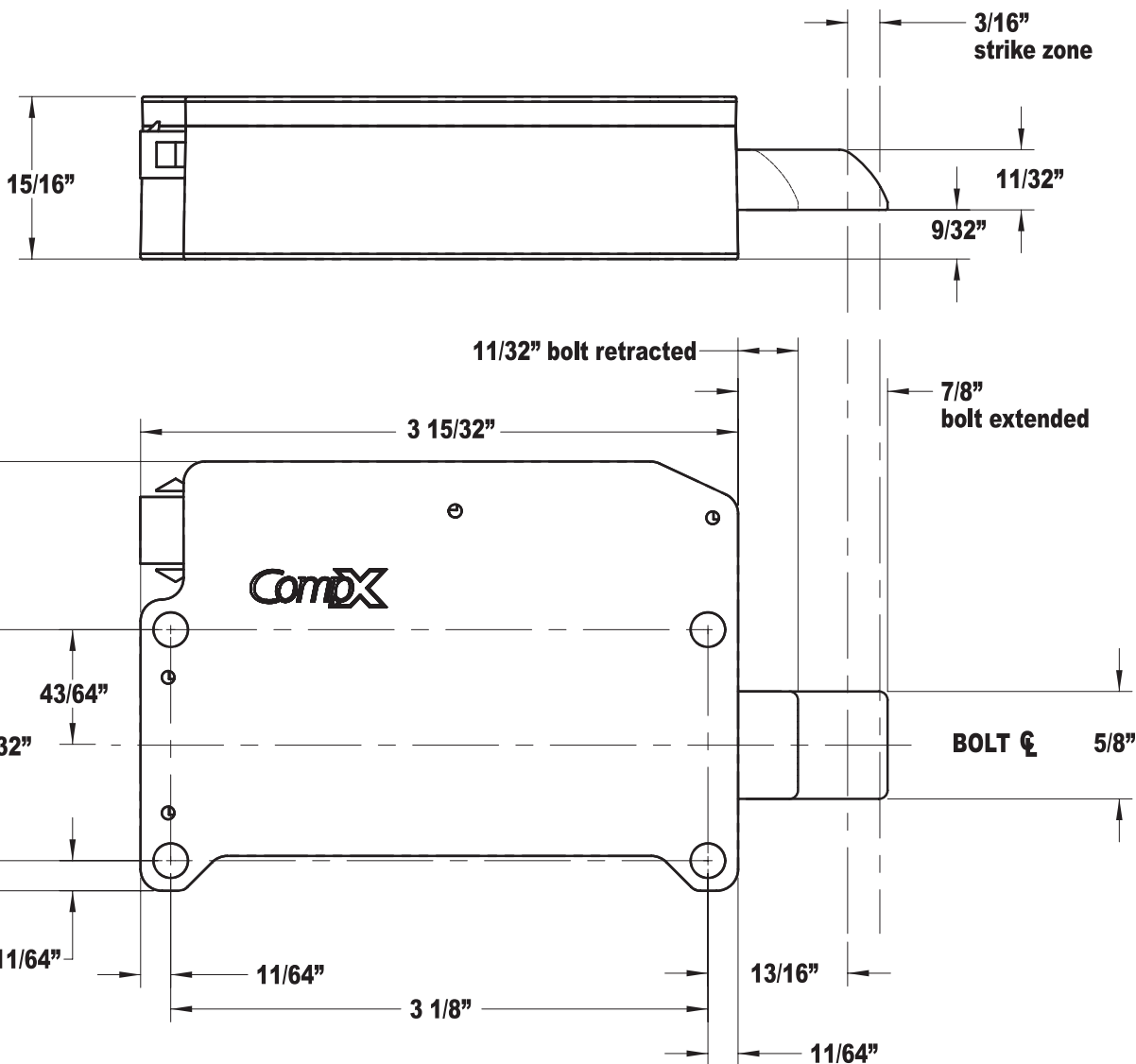
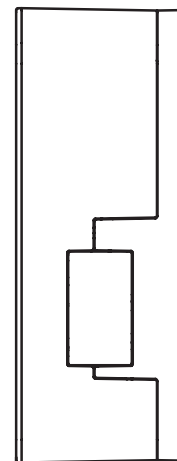
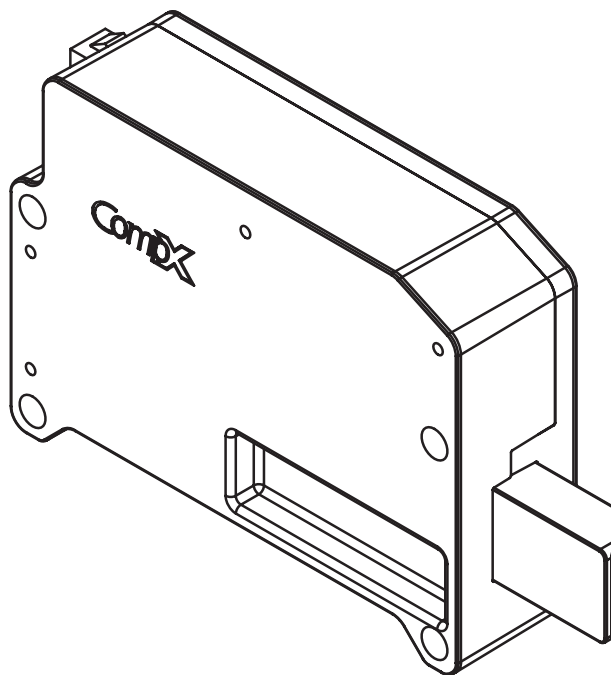

# SLAM BOLT LATCH (DECIMAL DIMENSIONS)



**NOTE:** \_\_\_\_\_ 1"

**NOT ACTUAL SIZE!**

Print this page and measure the line above. It is **ONE INCH LONG**. If it measures less than or more than one inch, the template measurements also need to be scaled accordingly.

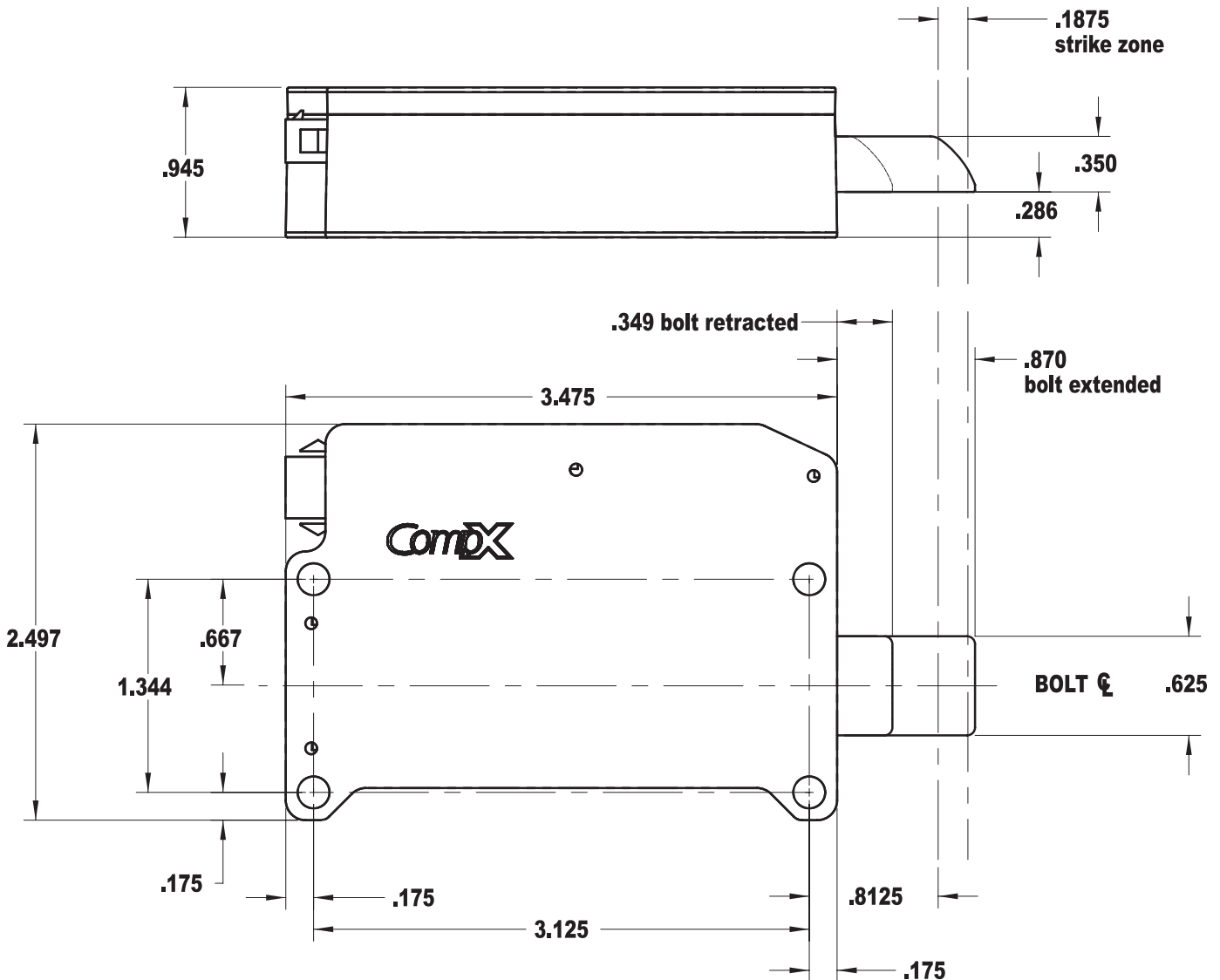
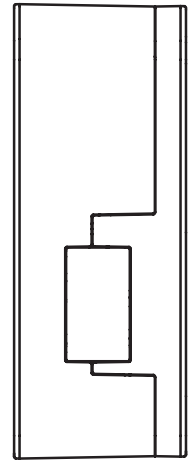
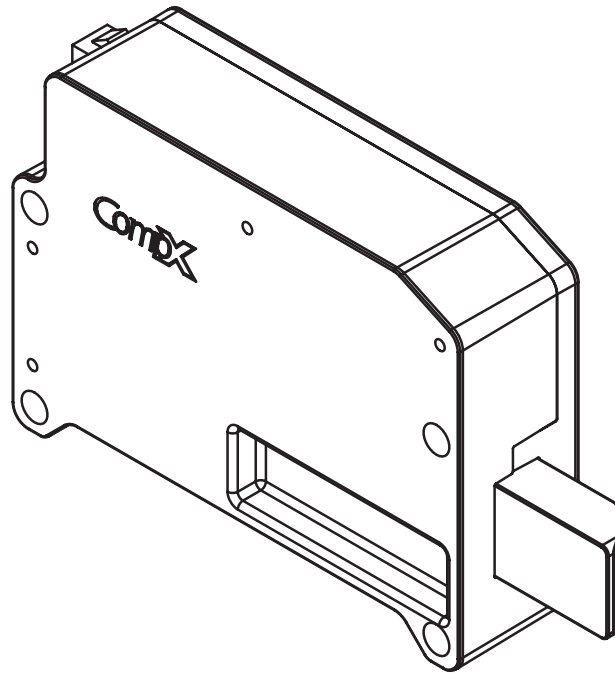



# TEMPERATURE MONITORING PROGRAMMING GUIDE

## CompX eLock® unit



### CompX eLock® unit

- A:** Green LED indicator of successful open cycle
- B:** Red LED indicator of unsuccessful attempt
- C:** Asterisk button used to clear entry or remove user / supervisors
- D:** Pound button used to insert PIN or program new users / supervisors

### \*\*\*IMPORTANT INFORMATION\*\*\*

This unit comes with factory reset codes/cards. Please save the attached stickers/cards and place in a secure location. This unit can be reset to original Factory Set-up Mode by entering the factory reset code or presenting the factory reset card. CAUTION: ENTERING THE FACTORY RESET MODE WILL ERASE ALL USERS/SUPERVISORS THAT ARE CURRENTLY PROGRAMMED IN THE LOCK.

#### Basic unit Features:

- ➔ Records 8,000 temperature events
- ➔ Accuracy within +/- 1°C
- ➔ Single probe, mounted in non-toxic glycol bottle
- ➔ Easy to read LCD display
- ➔ Operating range of from -40 °F to 122 °F (-40 °C to 50 °C)
- ➔ Requires 6 AA batteries (9V) not included

## CompX eLock® temperature display keypad

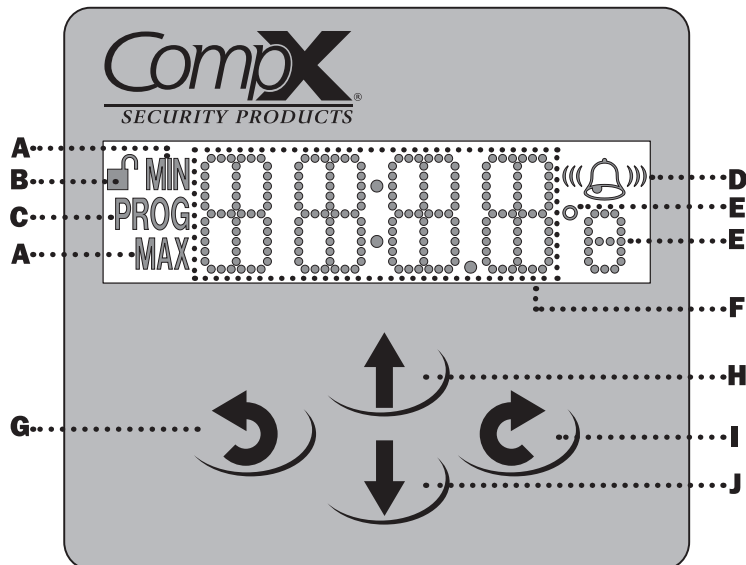



Note: not actual size; shown at 150%

### CompX eLock® temperature display keypad

- A:** Minimum and maximum temperature limits
- B:** Unit is unlatched. This icon is not visible when latching mechanism is in the locked position.
- C:** Programming mode
- D:** Bell icon indicates alarm is enabled. Flashing bell sound waves means the alarm is sounding. Flashing bell means the alarm has been muted. Does not indicate alarm volume setting: soft-medium-loud.
- E:** Degree sign and unit of temperature measure. Will either show °C or °F.
- F:** Display of time or temperature or setting.
- G:** Back button
- H:** Scroll up button
- I:** Enter button
- J:** Scroll down button

#### General functionality:

- ➔ Pressing the scroll up arrow will display the maximum temperature that the monitor has recorded
- ➔ Pressing the scroll down arrow will display the minimum temperature that the monitor has recorded
- ➔ Pressing the  key will display the current date
- ➔ Pressing the  key twice will display the day of the week

# TEMPERATURE MONITORING PROGRAMMING GUIDE *continued*

## Getting Started

- Unit is shipped in "Set-up" mode. Once 6AA batteries (not included) are installed, the LCD will say "SET up."



- Press and hold # (about three seconds) to get started.
- LCD will display STTime (set time). Hit



- Set Year using up and down arrows. Hit .
- Set Month using up and down arrows. Hit .
- Set Day using up and down arrows. Hit .
- Set Hour using up and down arrows. Hit .
- Set Minutes using up and down arrows. Hit .
- Display will show "Units." Hit .



- Choose °F or °C with up and down arrows. Hit .

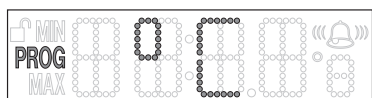

- Display will show "ALRM." Hit .

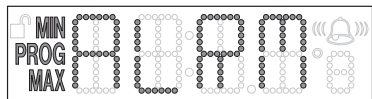

- Enable or disable alarm with up or down key. Hit .

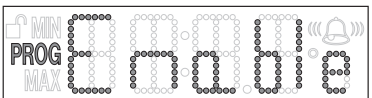

- If enabled, minimum degrees will appear. Adjust using up and down arrows and hit .
- Adjust Maximum degrees using up and down arrows and hit .
- If you want to disable the alarm, press the up or down arrow until it says "Enable - Okay No" and hit .



- Adjust speaker volume, 3 possible settings, LOUD, MED, SOFT, by using up and down keys and hit .

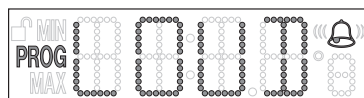
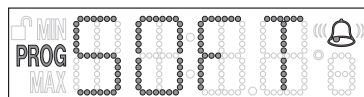
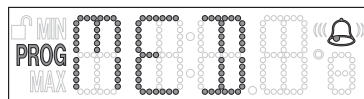

- The unit will display "Init ID" which is prompting you to program the initial credential. Remember, the first credential is always a Supervisor and goes into Slot 001.



- Enter PIN or present card followed by #.
- Unit will display "AGAIN" for confirmation of the code / card.

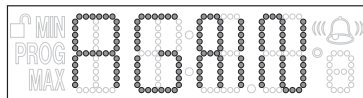

- Enter PIN or present card followed by # again.
- The unit is now successfully initialized. The LCD display will alternate time and temp.

## How to Change Modes After Initial Set-up

### ADDING USERS OR ADDITIONAL SUPERVISORS:

- Enter supervisor code/card and press #. Display will show "Supr."
- Press and hold # (again) for about three seconds.

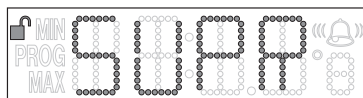

- Display will show "Add u" which means add user. If you use the up or down arrow, the display will show "Add s" which means add supervisor.
- Pick either "Add u" or "Add s" and hit .

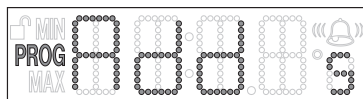
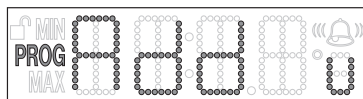

# TEMPERATURE MONITORING PROGRAMMING GUIDE *continued*

- The display will show the next available slot to program into. Hit (All entries done by slots will need to be logged.) Take the next available slot by pushing or program by specific slot by scrolling with the up and down buttons.

- The unit will display "READY."



- Enter PIN followed by # or present card.
- Unit will say "DONE."



- Unit will return to normal operating mode, showing alternating time and temp.

## DELETING USERS OR SUPERVISORS:

- Enter supervisor code / card and press #. Display will show "Supr."
- Press and hold \* for about three seconds.
- Display will show "DEL." Hit .



- At this point you can enter the PIN followed by # or present the card for the credential you want to remove.
  - If you want to delete by slot assignment, hit after you see "DEL" in the display.
  - The units will display "DL-Who." Use the up or down key to select the slot you want to clear and hit .

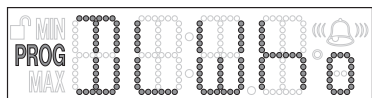

- Unit will display "ok-y" and alternate "slot."
- Hit to confirm. Unit will show "Done."



## Changing Lock settings

Enter supervisor code / card and press #. Display will show "Supr." Press and hold for about three seconds. Display will show

"ALRM" - use the up or down arrows to toggle between Units, St Time and ALRM modes. Hit on desired mode.

## UNITS

If Units is chosen, the eLock will allow you to select either F° or C°. Scroll using the up or down arrows until "Units" appears on the display and hit . Using the up or down key, select either F° or C° and press . The display will show "DONE" momentarily and then revert back to time and temperature.

## SET TIME (ST TIME)

If St Time is chosen, the eLock will allow you to adjust the time and date. Scroll using the up or down arrows until "St Time" appears on the display and hit .

Set Year using up and down arrows. Press .

Set Month using up and down arrows. Press .

Set Day using up and down arrows. Press .

Set Hour using up and down arrows. Press .

Set Minutes using up and down arrows. Press .

The display will show "DONE" momentarily and then revert back to time and temperature.

## ALARM (ALRM)

If ALRM is chosen and the alarm is Disabled, the LCD screen will read "Enable." Press to confirm ALRM enabling.

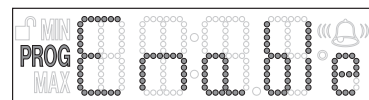

- Next screen will display "Limits" which allows you set the upper and lower limits of the alarm mode. Press to begin Limits programming
- Set minimum temperature and press
- Set maximum temperature and press
- The display will show "DONE" momentarily and then revert back to time and temperature

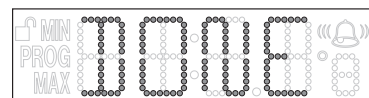

If ALRM is chosen and ALRM is Enabled, the LCD screen will display Limits. Use the up or down arrows to toggle between Limits, disable, A-Vol, MUTE, and R-SET. Select desired mode and press .

**TEMPERATURE MONITORING PROGRAMMING GUIDE** *continued*

**LIMITS (ALARM MUST BE ENABLED TO CHANGE THIS SETTING)**

Use this screen to set the upper and lower limits of the alarm mode.



1. If you choose Limits, the next screen will show you the minimum temperature. Press up or down buttons or enter via keypad until the desired minimum temperature is reached and press .

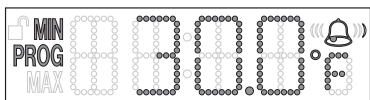

2. The next screen is your maximum temperature screen. Again, use the up or down buttons or enter via keypad until the desired maximum temperature is displayed and hit .

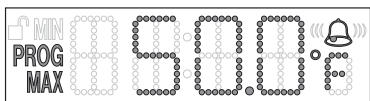

3. The unit will momentarily say "Done" and then revert back to time and temp.

**DISABLE (ALARM MUST BE ENABLED TO CHANGE THIS SETTING)**

If you choose Disable, the screen will allow you to turn the alarm off. Choose the desired setting and press . Press again to confirm.



**A-VOL: (Alarm must be enabled to change this setting)**



1. If you select Adjust Volume, you can pick the alarm volume level from three preset settings: LOUD, MED, Soft. Select desired setting and hit . DONE will appear momentarily and then the screen will revert back to Time and Temp. Factory default setting is MED.

**MUTE: (Alarm must be enabled to change this setting)**

1. Selecting the Mute setting will silence the alarm for 6 minutes. Select desired setting and hit . The bell icon on the LCD will flash indicating the alarm was muted.

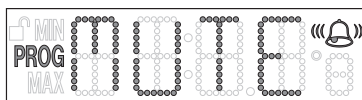

**RESET**

1. This function will reset the upper and lower temperatures the unit has recorded since the last time it was reset. It will not reset the upper and lower limits for alarming. If the alarm limits need to be changed, see previous section on "LIMITS."

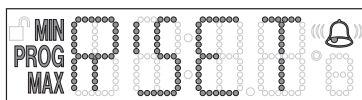

2. Hit on the R'set screen. The screen will prompt you "OK-y." Press to confirm.



**TO CHANGE ANY SETTING AFTER INITIAL SET-UP, A SUPERVISOR CODE WILL BE NEEDED.**

**TEMPERATURE-BUFFERED SENSOR**

The temperature probe (green bottle) provides and maintains accurate readings when refrigerator doors are opened.

Probe is sealed in a miniature bottle that simulates vials, and is filled with non-toxic glycol (recognized by the FDA as safe), eliminating concerns about incidental contact with food or medicines.

Self adhesive wire routing clips provided for your convenience. Bring wire over door, keeping the wire taut. Use wire routing clips to keep the wire in place. Wire is 10 feet long, allowing it to be used anywhere within the refrigerator.

It is highly recommended that this probe is placed on a shelf along with other medications and not on the inside of the refrigerator door.





# TEMPERATURE MONITORING PROGRAMMING GUIDE *continued*

## Step 1: Install the strike

There are two main parts of this installation: installing the strike and installing the eLock assembly. The strike and the eLock assembly can be mounted either with foam tape or by drilling holes and using screws. It is important to note that mounting the strike and the eLock assembly are independent of each other. One can be foam tape mounted, and one can be drill mounted if desired. The two do not need to be mounted using the same method.

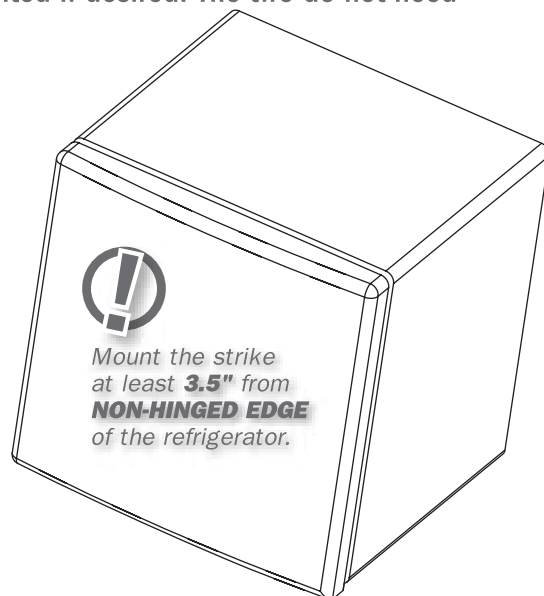
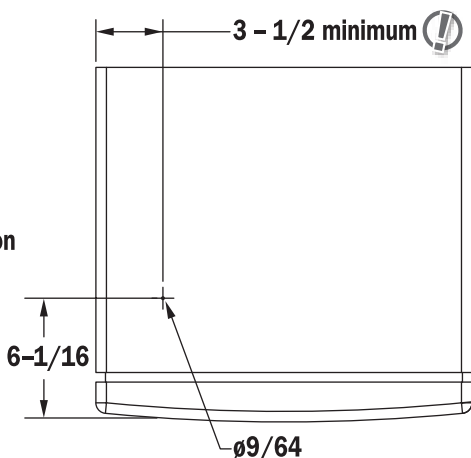
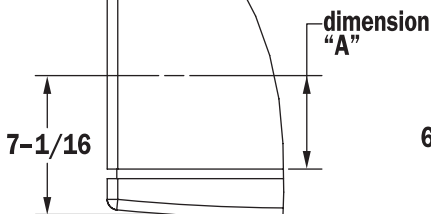
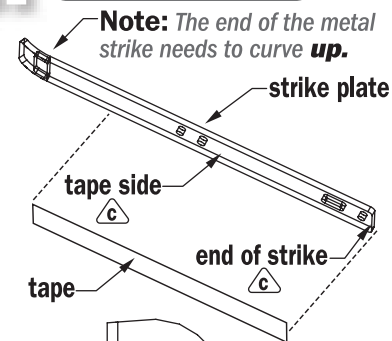

### Foam Tape Installation

Please note that if foam tape installation of the strike is used, the strike will **not** be adjustable once it's put in place.

- Clean top of both the refrigerator and the strike with rubbing alcohol. Wait for the alcohol to dry.
- With a pencil, mark refrigerator 7-1/16" from the front of the door and at least 3.5" from the non-hinged edge.

Measure from this line to the front of the cabinet (dim. "A"); cut a piece of tape this length.

- Remove tape backer and affix to end of strike. The upward curve should be on top. Apply tape to the opposite side. Remove backer. Line up strike with line on refrigerator; apply pressure to seal it on.

### Drilling Installation

- Before drilling, verify that there are no refrigerant lines inside the top of the refrigerator.
- Drill a 9/64" hole, 6-1/16" from the edge of the front of the refrigerator and at least 3.5" from the non-hinged edge of the refrigerator.

## Step 2: Secure the strike and attach the strike cover (if strike was mounted using foam tape, ONLY do b.)

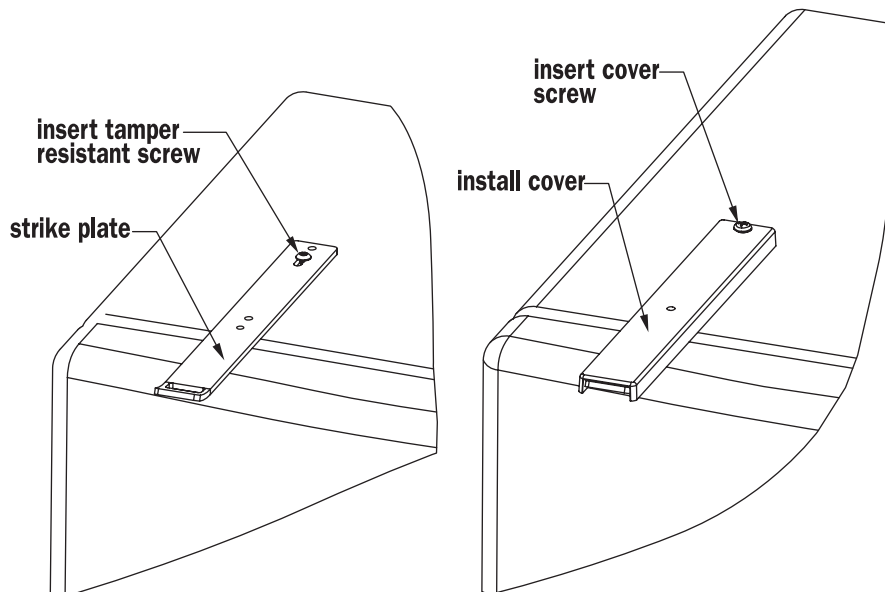

- Screw one tamper resistant sheet metal screw into the center of the strike's slotted area. **Note:** The end of the metal strike needs to curve **up**.
- Place the plastic strike cover over the metal strike. If strike was mounted using foam tape, please proceed to Step 3.
- Attach with one tamper resistant machine screw.

# TEMPERATURE MONITORING PROGRAMMING GUIDE *continued*

## Step 3: Mount the main CompX eLock® body to the refrigerator door

The CompX eLock® assembly (body) can be mounted to the front of the refrigerator either by using foam tape or by drilling holes.

### Foam Tape Installation

Please note that if foam tape installation of the strike is used, the main CompX eLock® will **not** be adjustable once it's put in place.

- Install one piece of double-sided tape on each side of the CompX refrigerator eLock assembly.
- Remove liner from double-sided tape.
- Carefully press CompX eLock® onto the center of the strike.

### Drilling Installation

- Click CompX eLock® onto strike.
- Push assembly up and center it on the strike.
- Drill six 9/64" holes through the housing into the refrigerator door for the mounting screws. Secure with screws. **Note:** Top two screws may be omitted if they interfere with door handle access.

**Note:** If foam tape was used to mount the strike, the CompX eLock® refrigerator kit installation is **COMPLETE**. The CompX eLock® may now be used.

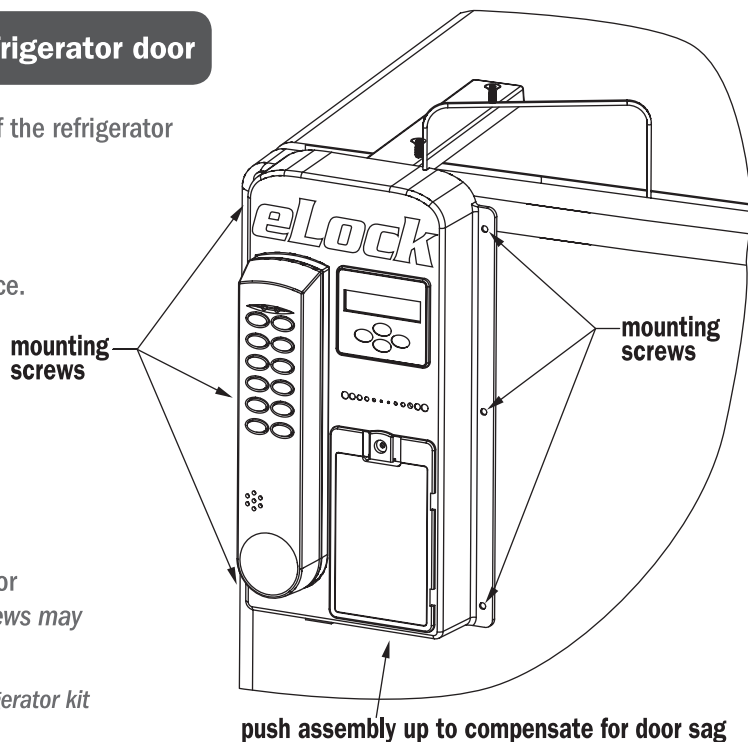

## Step 4: Finish installation of the strike (ONLY if drilled installation of strike was used)

- Remove the plastic cover from the strike plate. Drill 9/64" hole in second opening of strike.
- If adjustment of strike is needed, loosen up the first strike screw and adjust the strike. Tighten up the screw.
- Drill hole for second screw and install second screw.
- Reattach the plastic strike cover and attach with two tamper resistant machine screws.

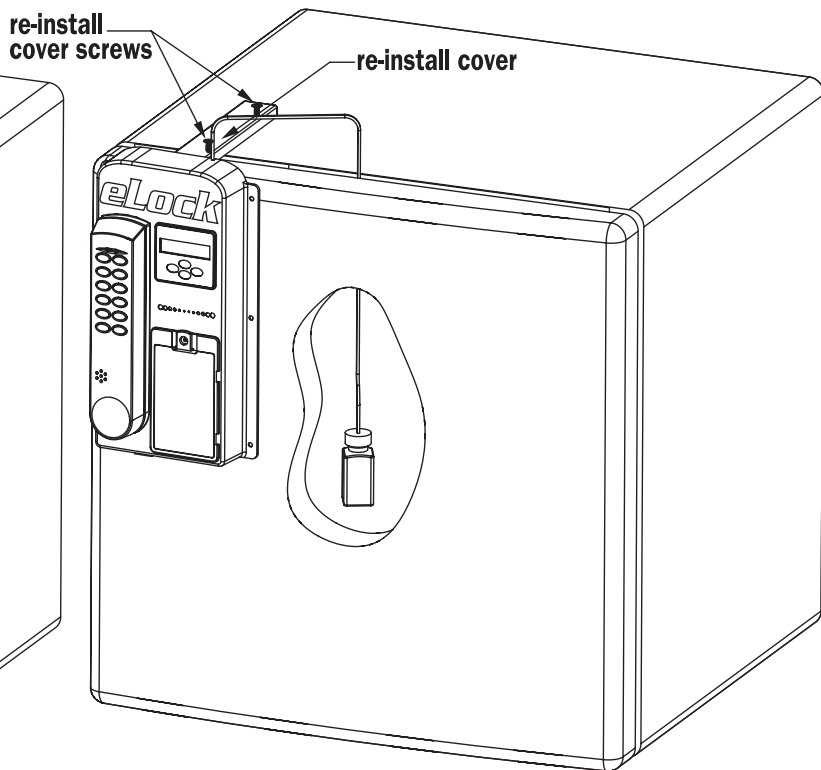
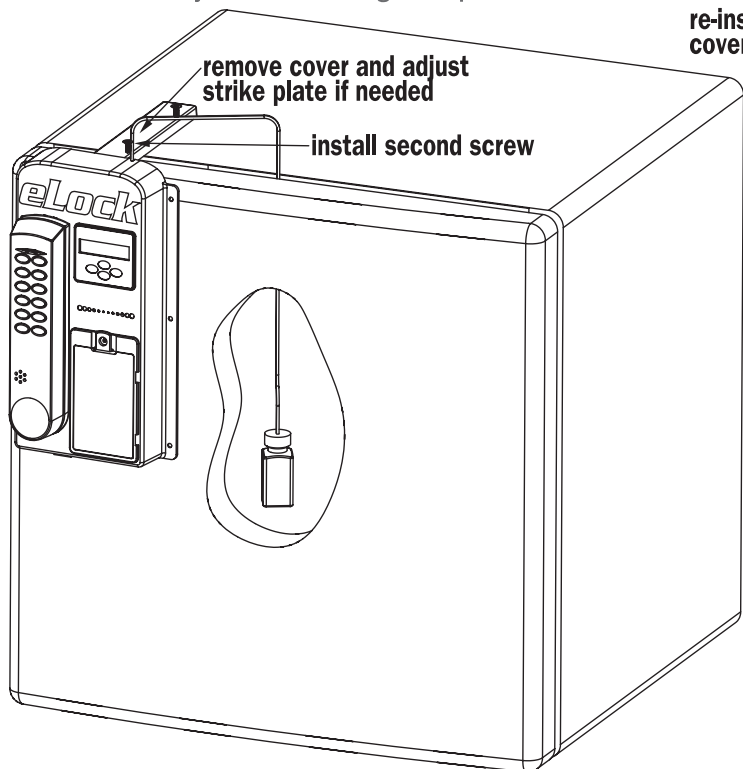

# TEMPERATURE MONITORING PROGRAMMING GUIDE *continued*

These stickers are included with each CompX eLock® unit. Please review the information and keep the stickers in a safe location as they may be needed to reset or identify a specific eLock unit. The codes shown here are not real codes. They are representations of what the stickers will look like.



**Sticker #1**

2d bar code. Provides the same information as sticker number three, but a 2d laser scanner is needed to decode the information.

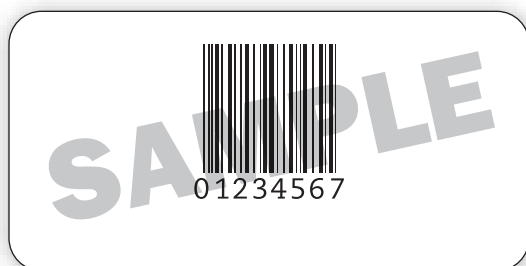

**Sticker #2**

1d bar code. Place this sticker on or around the CompX eLock® unit to help identify which codes to use if resetting the lock is necessary.

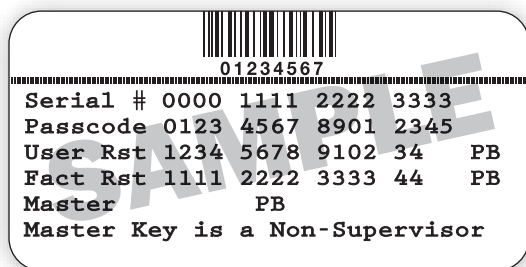

**Sticker #3**

**Keep this sticker in a safe location.**

**Serial #:** Needed to identify CompX eLock® units

**Passcode:** Unique to lock. Needed for LockView. Prevents unauthorized LockView use

**User Rst:** Allows administrator or owner to erase all user codes from eLock unit but keep supervisor codes

**Fact Rst:** Erases all codes from eLock, including settings. eLock unit will need to be set up again after a Factory Reset (see page 2)

**(SAMPLE) CompX eLock® Registration card**

Company \_\_\_\_\_ Phone# (    ) \_\_\_\_\_

Address \_\_\_\_\_

Authorized Contact \_\_\_\_\_

Position \_\_\_\_\_

Serial # \_\_\_\_\_

Pass Code \_\_\_\_\_

User Reset Code \_\_\_\_\_

Factory Reset Code \_\_\_\_\_

01234567

Serial # 0000 1111 2222 3333

Passcode 0123 4567 8901 2345

User Rst 1234 5678 9102 34 PB

Fact Rst 1111 2222 3333 44 PB

Master PB

Master Key is a Non-Supervisor

**Sticker #3**

**NOTE:** Don't forget to fill out and return your **WARRANTY CARD!**

Affix one copy of sticker #3 to the CompX eLock® registration card and return to CompX Fort at address shown on the other side of the registration card.

**TEMPERATURE MONITORING PROGRAMMING GUIDE** *continued*

**Accessories**



**HID® PROX USER, SUPERVISOR CARD**

Part Number:  
**EL-2004-PC** (no logo)  
**EL-2004-PC-S** (CSP logo)



**MAGSTRIPE USER, SUPERVISOR CARD**

Part Number:  
**EL-2004-MSC** (no logo)  
**EL-2004-MSC-S** (CSP logo)



**LOCKVIEW® 3.0 SOFTWARE KIT**

(provided with 7ft., 6-pin RJ11 cable, 1-USB dongle, 1 LockView® CD)

Part Number:  
**EL-LOCKVIEW-3**



**HID® PROX TAG**

Part Number:  
**EL-2004-PT**



**SCREWDRIVER**

Part Number:  
**EL-DRV-15**

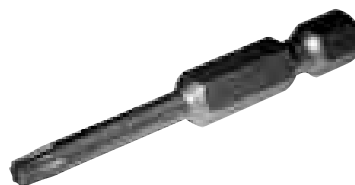

**BIT**

Part Number:  
**EL-BIT-15**

HID is a trademark of HID Corporation.

\* These items are offered as Service / Replacement Parts only.

**LockView® 3.0 Software**

- Add, edit, view and delete users / supervisors and their credentials
- Add, edit and delete CompX eLocks®
- Assign access rights between users / supervisors and CompX eLocks® in the database
- USB connection required
- Download, view, save, print, archive and delete audit trails
- Dual credential access available
- Set real time clock
- Time based access restrictions
- Create user groups
- Windows™ based
- View Temperature Logs
- View Temperature Graphs
- Edit Temperature Settings

LockView is a Registered Trademark of CompX International. Windows is a trademark of the Microsoft Corporation. Specifications may vary based on user application.





# LockView<sup>®</sup> 3.0 software Instruction Manual

**864.297.6655**

[compX.com](http://compX.com)

PO Box 200  
Mauldin, SC 29662

Copyright 2007  
© CompX Security Products

**CompX**<sup>®</sup>  
SECURITY PRODUCTS