

300 series

Network Cabinet eLock

(((WIRELESS OR ETHERNET READY)))



Access Control features:

- ◆ Easy installation on existing or new cabinets made of wood or metal, etc.
- ◆ 3,000 user/supervisor codes
- ◆ Six modes of access: Keypad, Proximity card* HID, iCLASS, iCLASS SE, MiFARE and DESFire smart cards *Use existing identification cards
- ◆ Motor-driven latching mechanism provides the convenience of automatic relocking
- ◆ eLock is capable of operating two latches or doors
- ◆ 6-AA battery pack; premium brand Alkaline batteries recommended (not included)
- ◆ Low battery indicator
- ◆ “Jump Start” 9-volt battery power port allows the user, with a valid credential, to access the CompX eLock® when the batteries are exhausted
- ◆ Programming can be done manually on user-friendly LCD blue backlit screen or through LockView® software
- ◆ Compatible with 12-volt electric door strikes to control access on interior doors
- ◆ Optional door switch provides instant notification of unauthorized entry or door ajar alerts



Network features:

- ◆ Utilizes 802.11 b/g/n - 2.4 / 5.0 GHz wireless protocol or Ethernet communication on existing networks
- ◆ Enables two-way communication via common security encryption methods: WEP 64-key, WEP 128-key, WPA-PSK (TKIP), WPA2-PSK (AES) and other enterprise-class wireless security

Non-network units also available.
Visit compxelock.com for all eLock solutions.

CompX
SECURITY PRODUCTS

Reorder #: F2644-029

Copyright 2021 © CompX Security Products / 847.752.2500 / compx.com / 715 Center St., Grayslake, IL 60030
Any companies and/or products referred to herein are marks or registered trademarks of their respective companies, owners and/or mark holders.

For more information, call **847.752.2500**

LockView SOFTWARE

LockView 5/5Pro is easy to use, with many programmable options, and allows access to any eLock from any computer on the network.

LockView® 5 Pro software features:

- ◆ Provides a comprehensive audit trail of the last 15,000 access attempts; including date, time and user name
- ◆ Escalating notification system sends alerts via email; optional Short Message Service provides Text Message, Voice Messaging or Fax alerts
- ◆ Complies with Joint Commission standards and is 21 CFR Part 11 compliant
- ◆ Compliance Dashboard provides at-a-glance status of all eLocks on the network
- ◆ LockView enables updates via the network to any eLock on the system. Updates can include:
 - User changes (Add / Delete / Modify Credentials)
 - eLock Changes (Add / Delete / Modify eLocks)
 - Access Rights changes

Minimum System Requirements

Windows 7, 8, 8.1, 10, Server 2008/2012/2016/2019 and R2 versions. 4GB RAM (8GB recommended), Processor 2.0 GHz or higher, 4GB Hard drive space, SQL Server Standard, Enterprise, or SQL Express 2008/2012/2014/2016/2017/2019 and R2 versions. Supports up to TLS 1.2. Other configurations are acceptable; please consult factory for detailed information.



Network cabinet eLock has three components:

Controller

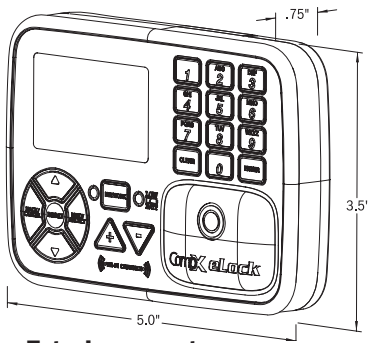

Exterior mount

Motorized gear-driven latch

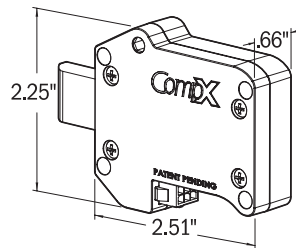

Interior mount

Battery compartment

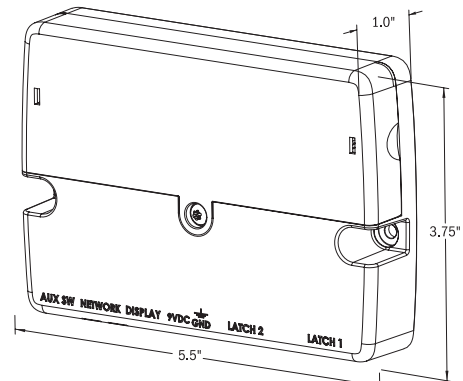

Reorder #: F2644-029

Copyright 2021 © CompX Security Products / 847.752.2500 / compx.com / 715 Center St., Grayslake, IL 60030
Any companies and/or products referred to herein are marks or registered trademarks of their respective companies, owners and/or mark holders.

For more information, call **847.752.2500**