

150 Series

CompX refrigerator eLock Instructions



Thank you for purchasing the CompX eLock. The information contained in these instructions is intended

to serve as a guide so as to allow the eLock to be quickly and easily put into service.

150 series refrigerator eLock

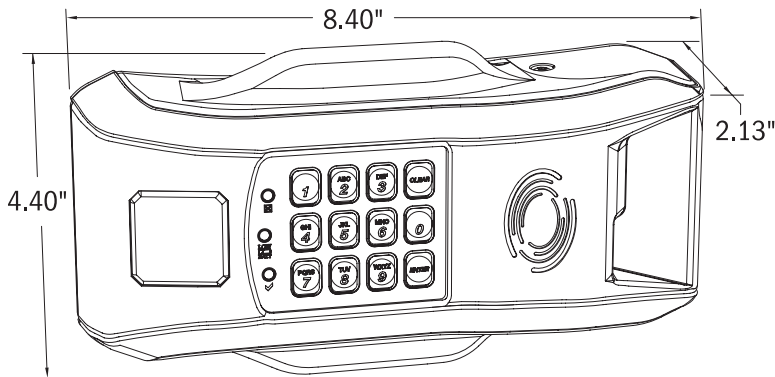

Unit Features:

- ◆ Each eLock can hold any combination of up to 250 Supervisors and Users
- ◆ Choose a model to use existing HID Prox or HID iCLASS credentials that can be programmed to operate each eLock
- ◆ Spring bolt latching mechanism provides automatic relocking
- ◆ Door position switch input (requires additional hardware)
- ◆ Membrane keypad provides durable performance and easy cleaning

What's in the box?

- ◆ 1 - eLock
- ◆ 1 - eLock mounting plate
- ◆ 1 - strike plate
- ◆ 1 - strike plate cover
- ◆ 8 - #8 x 3/8" Phillips flat head sheet metal screw (mounting plate)
- ◆ 2 - #8 x 1/2" pin-in Torx pan head sheet metal screw (strike plate)
- ◆ 2 - #8 x 1/2" pin-in Torx flat head machine screw (strike plate cover)
- ◆ 1 - 7" foam tape (strike plate)
- ◆ 3 - 5" foam tape (mounting plate and strike plate)
- ◆ 1 - battery compartment
- ◆ 1 - warranty card
- ◆ 1 - serial code sticker set (keep in a secure location)
- ◆ 1 - in-box instructions

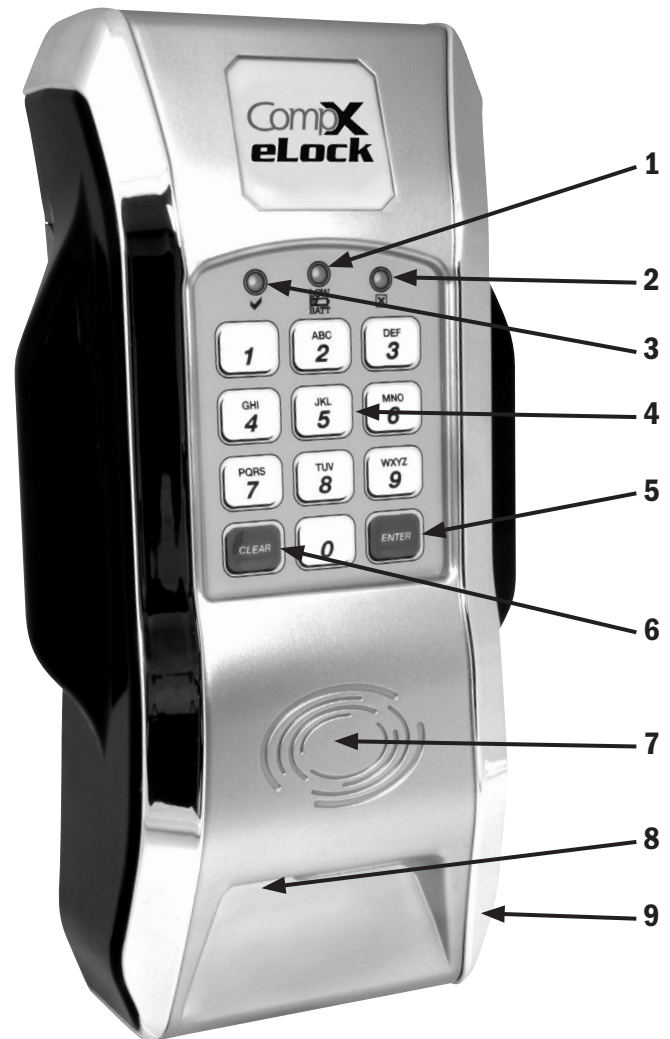

eLock controller

- | | |
|--|---|
| 1. Low battery indicator (yellow LED) | 7. HID Prox or HID iCLASS reader location (if equipped) |
| 2. <input checked="" type="checkbox"/> Red LED | 8. USB Port for direct connection to LockView software |
| 3. <input checked="" type="checkbox"/> Green LED | 9. AA Battery pack - 6 (BATTERIES NOT INCLUDED) |
| 4. Alpha-numeric keypad | |
| 5. "ENTER" button | |
| 6. "CLEAR" button | |

150 Series Refrigerator eLock – Programming

What's needed?

- ◆ 6 – premium brand AA alkaline batteries
- ◆ Drill
- ◆ #2 philips head bit
- ◆ T15 pin-in Torx (6-lobe) bit or driver (secures battery compartment and strike plate cover screws)
- ◆ Rubbing alcohol
- ◆ Level

Care and Cleaning

The eLock is a battery operated device. Therefore, it should be part of a regular battery maintenance program.

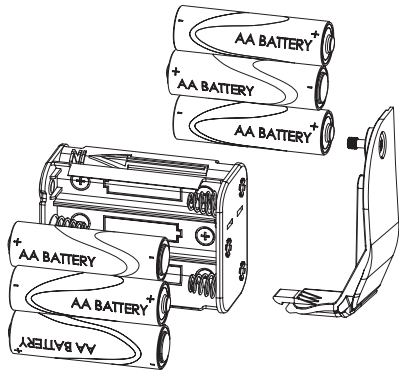

To clean the surface of the eLock controller, apply non-acid based cleaner to a clean cotton cloth; do not spray cleaner directly on the controller. Wipe down keypad and housing taking care around the USB and edges of keypads. Wipe excess cleaner off of all surfaces.

Setting up the eLock

Install 6 AA alkaline batteries. (not included).

Warning: install the batteries as shown in the battery compartment. Polarity (+) or (-) must be correct. Replace batteries as a set. Always use new batteries when replacing the old set. Do not combine a used battery with a new one. Only use premium alkaline batteries; do not mix battery types.

GETTING STARTED

The eLock is shipped with no PIN or if equipped card credentials.

There are 2 levels of credential: User / Supervisor.

Only a Supervisor credential(s) is allowed to manually program

Note: Green LED on reader will flash upon presenting a valid Supervisor level credential, versus a solid green LED upon presenting a User level credential

INITIAL PROGRAMMING OUT OF THE BOX or AFTER A FACTORY RESET HAS BEEN PERFORMED

(See page 3 for FACTORY RESET instructions)

1. Press and hold “ENTER” until the beeping stops
2. Enter PIN (4 to 14 digits) and press “ENTER” or present card (if equipped)

This PIN / card is now a Supervisor level credential occupying slot 001

The maximum number of slots per eLock is 250

TO ADD A USER

1. Input a valid Supervisor PIN and press “ENTER” or present valid Supervisor card
2. Press and hold “ENTER” until beeping stops
3. Input the new User PIN and press “ENTER” or present new User card

TO ADD A SUPERVISOR

1. Input a valid Supervisor PIN and press “ENTER” or present valid Supervisor card
2. Press and hold “ENTER” until beeping stops
3. Press and hold “ENTER” again until beeping stops
4. Input new Supervisor PIN and press “ENTER” or present NEW Supervisor card

TO DELETE A USER OR SUPERVISOR

1. Input a valid Supervisor PIN and press “ENTER” or present valid Supervisor card
2. Press and hold “CLEAR” until beeping stops
3. Input the PIN to be deleted and press “ENTER” or present existing card to be deleted

TO ADD A USER WITH A SPECIFIC SLOT ASSIGNMENT

1. Input a valid Supervisor PIN and press “ENTER” or present valid Supervisor card
2. Press and hold “ENTER” until beeping stops
3. Enter slot number that will be assigned to user and press (Example: to program slot 18 type 018)
4. Input the new PIN (4 digit min) and press “ENTER” or present NEW card

150 Series Refrigerator eLock – Programming / Operation

TO DELETE A USER WITH A SPECIFIC SLOT ASSIGNMENT

1. Input a valid Supervisor PIN and press “ENTER” or present valid Supervisor card
2. Press and hold “CLEAR” until beeping stops
3. Enter slot number to be cleared and press “ENTER” (example: to clear slot 6 type 006)
4. Enter slot number to be cleared again and press “ENTER” (example: to clear slot 6 type 006)

OPERATION INSTRUCTIONS

Follow the below instructions to open the eLock

KEYPAD: Enter in a valid PIN (4 to 14 digits) and press “ENTER”.

CARD: If the eLock is also equipped with a card reader (HID Prox or HID iCLASS), present a valid card.

DUAL CREDENTIAL: If the valid Supervisor/User is a dual credential (programmable only in LockView) enter the first credential (PIN or card) and then enter the second credential (PIN) and press “ENTER”. Note the second credential must be a 4 to 14 digit PIN.

The latch bolt will extend automatically after the factory default time or custom programmed time as set in LockView has expired - press “CLEAR” to extend the bolt immediately.

SETUP MODE: Required to allow the eLock to be added to LockView software and to perform a FACTORY RESET. Press and hold “CLEAR” until the audible beeping stops. Enter the SETUP CODE (Setup Cd) and press “ENTER”. See green sticker set for setup code.

FACTORY RESET

WARNING: FACTORY RESET will delete all previously programmed credentials

With the eLock in SETUP MODE, while pressing and holding “CLEAR”, press and continue to hold “8” and then press “6”. The eLock will make a short series of audible major tones and the green LED will blink continuously. Programming can begin again as if the eLock was “OUT OF THE BOX” (see page 2).

Methods to begin building a database of eLocks in CompX’s LockView Software

For complete details on how to build a database of users and eLocks, see the *CompX LockView Software Instruction Manual*.

CompX LockView Software v5 (not included) must be installed and the eLock must be in **SETUP** mode before continuing. See page 3 for Setup Mode Instructions.

Stand-alone eLocks (Direct USB connection to laptop computer with LockView is required) There are two methods that can be used to add eLocks to the LockView software.

Automatic Method

Note: Supervisors and/or Users that already exist in the eLock will automatically be carried into LockView once the eLock has been enrolled.

1. With the eLock in **SETUP** mode, connect the eLock via the USB cable to the computer on which LockView is installed.
2. Login to LockView.
3. After 30 seconds, the below will appear.

*NOTE: After 5 minutes of inactivity, the eLock will exit **SETUP** mode.*

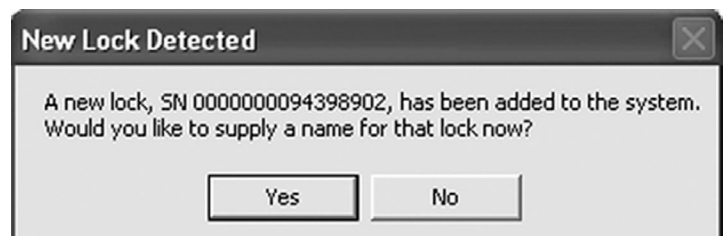

4. Click **Yes**.
5. The below will appear. Type in the name of the lock.

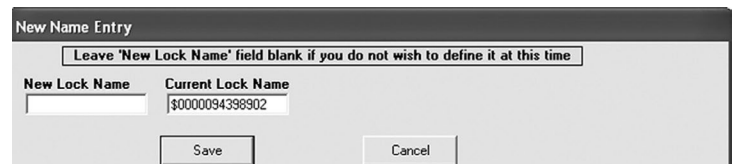

6. Click **Save** when done.
7. Go to **Lock Editor** tab in **Lock/User Editor**.

150 Series Refrigerator eLock – Programming / Operation continued

8. Left click to highlight the name of the lock and then click **Edit Lock**.
 9. Verify and/or adjust all other lock parameters. (**See LockView Instruction Manual for complete details.**)
 10. Click **OK** when done.
- Manual Method**
Note: Any existing Supervisor and /or User credentials that have already been manually programmed in the eLock will be removed. If it is desired to keep existing credentials, choose the Automatic Method to enroll the eLock.
1. Login to LockView.
 2. Go to **Lock/User Editor; Lock Editor** tab and click **Add Lock**.
 3. Enter the required information: **Lock Name; Lock Serial Number** and **Setup Code** (supplied on green sticker set as Setup Cd).
 4. Verify and/or adjust all other lock parameters and click **OK**. (**See LockView Instruction Manual for complete details on these options**)
 5. After 30 seconds, the lock will be updated in LockView. Click **Refresh** to prompt the update.

150 Series – Installing the vertical mount refrigerator kit

• **VERIFY ELOCK OPERATION BEFORE BEGINNING INSTALLATION** •

Step 1: Install the strike

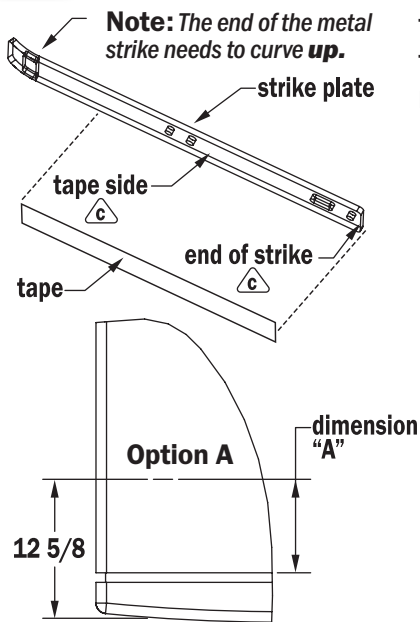

There are two main parts of this installation: installing the strike and installing the eLock assembly. The strike and the eLock assembly can be mounted either with foam tape or by drilling holes and using screws. It is important to note that mounting the strike and the eLock assembly are independent of each other. One can be foam tape mounted, and one can be drill mounted if desired. The two do not need to be mounted using the same method.

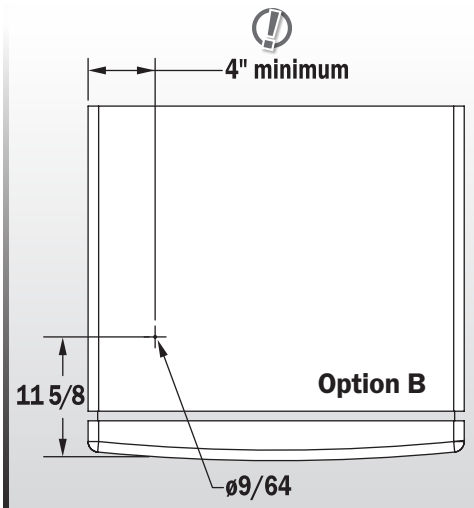
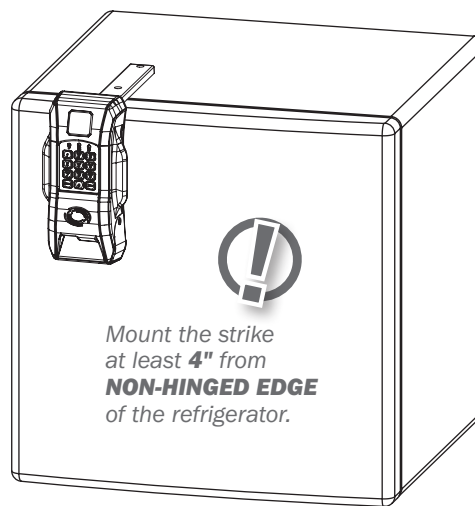

Foam Tape Installation: Option A

Please note that if foam tape installation of the strike is used, the strike will **not** be adjustable once it's put in place.

- a. Clean the top refrigerator as well as the strike with rubbing alcohol. Wait for the alcohol to dry.
- b. With a pencil, mark refrigerator 12-5/8" from the front of the door and at least 4" from the non-hinged edge.

Measure from this line to the front of the cabinet (dim. "A"); cut a piece of tape this length.

- c. Remove tape backer and affix to end of strike. The upward curve should be on top. Apply tape to the opposite side. Remove backer. Line up strike with line on refrigerator; apply pressure to seal it on.

Drilling Installation: Option B

- a. Before drilling, verify that there are no refrigerant lines inside the top of the refrigerator.
- b. Drill a 9/64" hole, 11-5/8" from the edge of the front of the refrigerator and at least 4" from the non-hinged edge of the refrigerator.

150 Series – Installing the vertical mount refrigerator kit continued

Step 2: Secure the strike and attach the strike cover (if strike was mounted using foam tape, ONLY do b.)

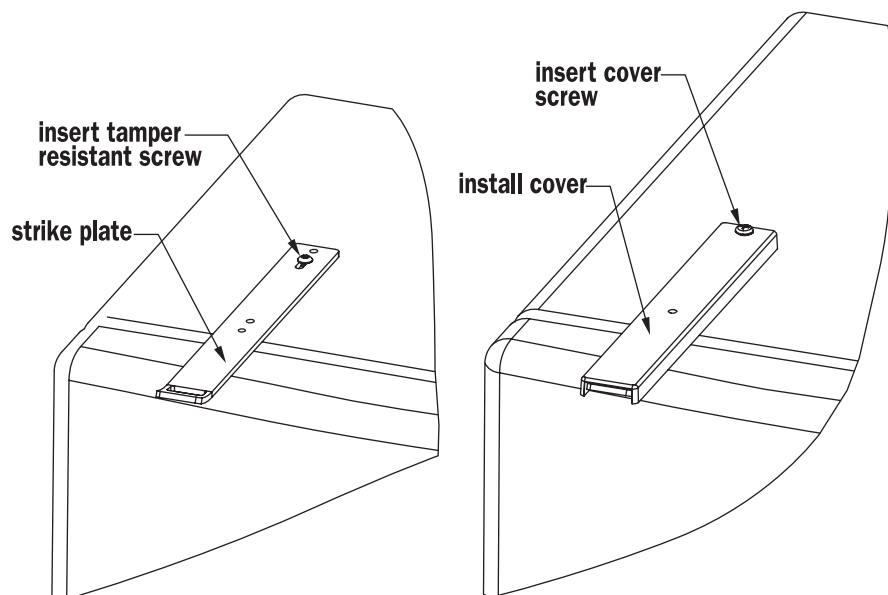

- Screw one tamper resistant sheet metal screw into the center of the strike's slotted area. **Note:** The end of the metal strike needs to curve **up**.
- Place the plastic strike cover over the metal strike. If strike was mounted using foam tape, please proceed to Step 3.
- Attach with one tamper resistant machine screw.

Step 3: Mount the main CompX eLock® body to the refrigerator door

The CompX eLock can be mounted to the front of the refrigerator by using the provided foam tape or by drilling holes and using screws (provided).

Foam Tape Installation

Please note that if foam tape installation is used, the eLock will **not** be adjustable once it is put in place.

- Clean the front of the refrigerator with rubbing alcohol. Wait for the alcohol to dry.
- Click the eLock onto strike plate, ensuring proper latch bolt engagement and mark the eLock location on the refrigerator door with a pencil.
- Remove one side of the protective liner from the double-sided tape and install on the CompX refrigerator eLock mounting plate.
- Attach the mounting plate to the back of the eLock.
- Remove remaining protective liner from double-sided tape.
- Carefully press eLock onto the refrigerator door in the location as previously marked.
- Verify proper operation and alignment.
- Firmly press eLock onto fridge. **Note:** Temporary support of the eLock may be required to allow adequate adhesion time of the foam tape.



Drilling Installation

- Cut a 3" piece of double-sided foam tape and attach it to the mounting plate to serve as an location alignment holder.
- Attach the mounting plate to the back of the eLock.
- Click the eLock onto strike plate, ensuring proper latch bolt engagement. Press eLock onto the refrigerator door.
- Remove eLock from mounting plate by pressing down on the mounting plate release tab.
- Drill eight 9/64" holes through the mounting plate holes into the refrigerator door. Secure with mounting plate screws.
- Attach eLock to mounting plate.
- Verify proper operation and alignment.

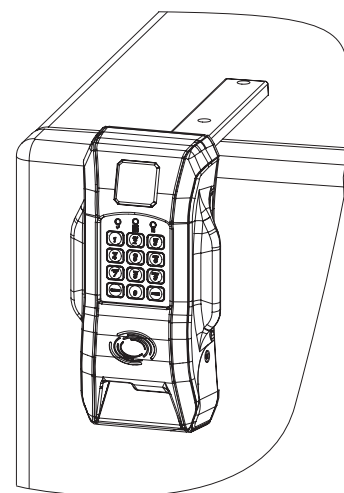

Note: If foam tape was used to mount the strike, the eLock refrigerator kit installation is COMPLETE.

150 Series – Installing the **vertical** mount refrigerator kit continued

Step 4:

Finish installation of the strike (ONLY if drilled installation of strike was used)

- Remove the plastic cover from the strike plate. Drill 9/64" hole in second opening of strike.
- If adjustment of strike is needed, loosen the first strike screw and adjust the strike. Tighten the screw.
- Drill hole for second screw and install second screw.
- Attach the plastic strike cover with two tamper resistant machine screws.

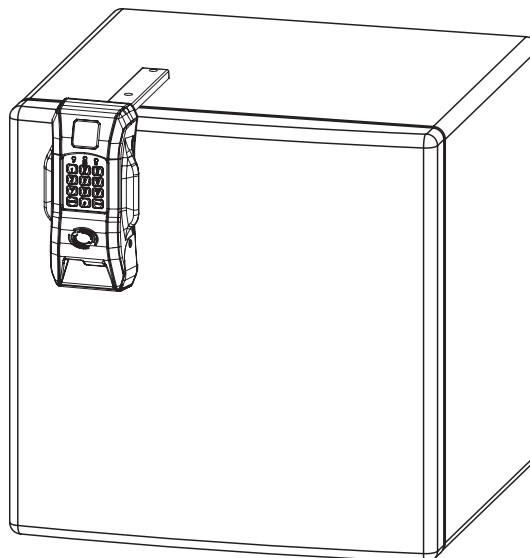

150 Series – Installing the **horizontal** mount refrigerator kit

Step 1:

Install the strike

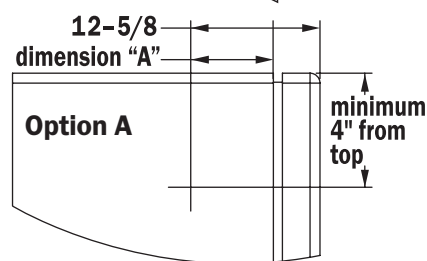
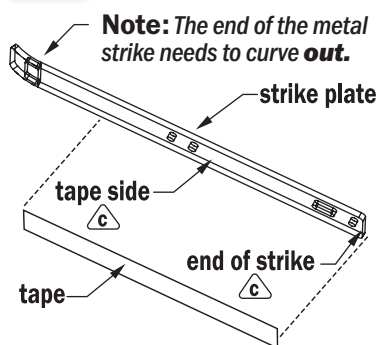

Foam Tape Installation: Option A
Please note that if foam tape installation of the strike is used, the strike will **not** be adjustable once it's put in place.

- Clean the side of the refrigerator as well as the strike with rubbing alcohol. Wait for the alcohol to dry.
- Along the non-hinged side of the refrigerator, make a mark 12-5/8" from

• VERIFY ELOCK OPERATION BEFORE BEGINNING INSTALLATION •

There are two main parts of this installation: installing the strike and installing the eLock assembly. The strike and the eLock assembly can be mounted either with foam tape or by drilling holes and using screws. It is important to note that mounting the strike and the eLock assembly are independent of each other. One can be foam tape mounted, and one can be drill mounted if desired. The two do not need to be mounted using the same method.

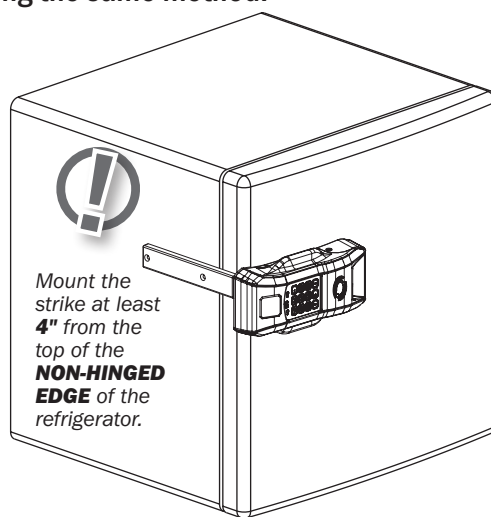

the front edge of door and a minimum of 4" from the top. Measure from this line to the front of the cabinet (dim. "A"); cut a piece of tape this length.

- Remove tape backer and apply tape. Line up end of strike with the 12-5/8" mark on side of refrigerator. Ensure strike is level, and apply using firm pressure. Install plastic strike cover on metal strike. Proceed to step 3.

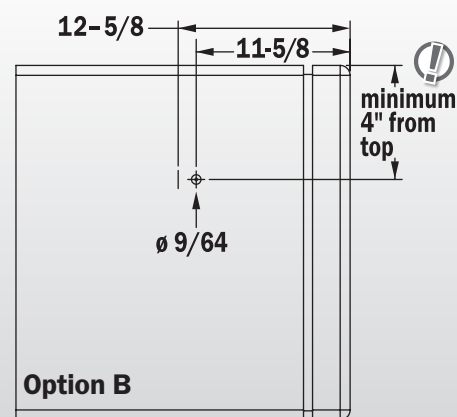

Drilling Installation: Option B

- Before drilling, verify that there are no refrigerant lines inside the side of the refrigerator.
- Drill a 9/64" hole, 11-5/8" back from the edge of the front of the refrigerator door and at least 4" from the top of the non-hinged edge of the refrigerator.

150 Series – Installing the **horizontal** mount refrigerator kit

Step 2:

Secure the strike and attach the strike cover

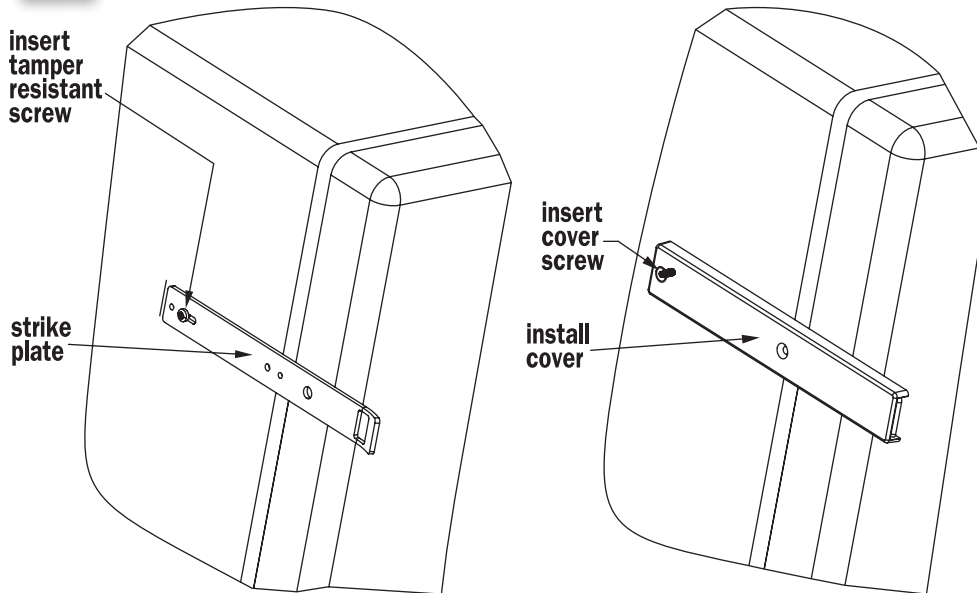

- Screw one tamper resistant sheet metal screw into the center of the strike's slotted area. **Note: The end of the metal strike needs to curve out.**
- Place the plastic strike cover over the metal strike.
- Attach with one tamper resistant machine screw.

Step 3:

Mount the CompX eLock® housing to the refrigerator door

The CompX eLock can be mounted to the front of the refrigerator by using the provided foam tape or by drilling holes and using screws (provided).

Foam Tape Installation

Please note that if foam tape installation is used, the eLock will **not** be adjustable once it is put in place.

- Clean the front of the refrigerator with rubbing alcohol. Wait for the alcohol to dry.
- Click the eLock onto strike plate, ensuring proper latch bolt engagement and mark the eLock location on the refrigerator door with a pencil.
- Remove one side of the protective liner from the double-sided tape and install on the CompX refrigerator eLock mounting plate.
- Attach the mounting plate to the back of the eLock.
- Remove remaining protective liner from double-sided tape.
- Carefully press eLock onto the refrigerator door in the location as previously marked.
- Verify proper operation and alignment.
- Firmly press eLock onto fridge. **Note: Temporary support of the eLock may be required to allow adequate adhesion time of the foam tape.**

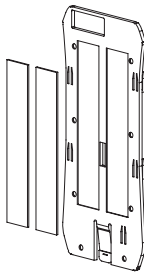

Drilling Installation

- Cut a 3" piece of double-sided foam tape and attach it to the mounting plate to serve as a location alignment holder.
- Attach the mounting plate to the back of the eLock.
- Click the eLock onto strike plate, ensuring proper latch bolt engagement. Press eLock onto the refrigerator door.
- Remove eLock from mounting plate by pressing down on the mounting plate release tab.
- Drill eight 9/64" holes through the mounting plate holes into the refrigerator door. Secure with mounting plate screws.
- Attach eLock to mounting plate.
- Verify proper operation and alignment.

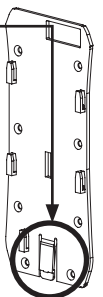
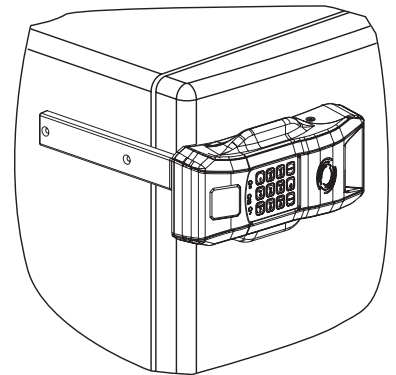

Note: If foam tape was used to mount the strike, the eLock refrigerator kit installation is COMPLETE.

150 Series – Installing the **horizontal** mount refrigerator kit continued

Step 4:

Finish installation of the strike (ONLY if drilled installation of strike was used)

- Remove the plastic cover from the strike plate. Drill 9/64" hole in second opening of strike.
- If adjustment of strike is needed, loosen up the first strike screw and adjust the strike. Tighten up the screw.
- Drill hole for second screw and install.
- Reattach the plastic strike cover and secure with two tamper resistant machine screws.

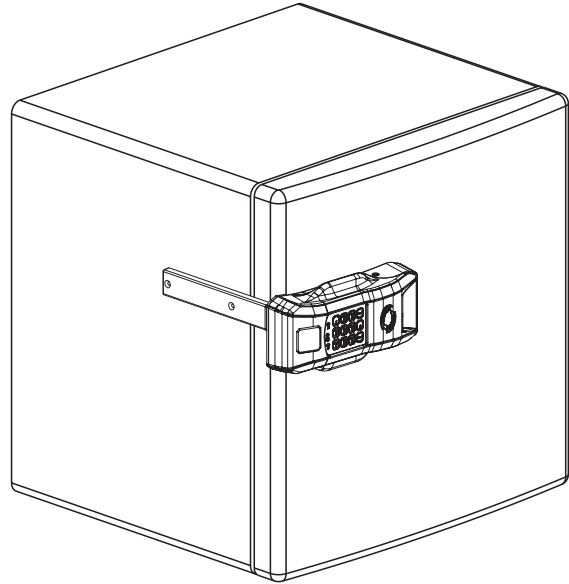

150 Series Refrigerator eLock – Accessories



HID® Prox User, Supervisor Card

Part Number:
EL-2004-PC (no logo)

EL-ICLASS-C
(HID iCLASS user, supervisor card)



HID® Prox Tag

Part Number:
EL-2004-PT

EL-ICLASS-T
(HID iCLASS tag)

Note: product images are not to scale.
HID is a trademark of HID Corporation.



LockView® Software Kit (1 LockView® travel drive, 1 USB cable)

Part Number:
LOCKVIEW-5PRO



Bit (T-15 pin-in-head Torx 6-lobe)

Part Number:
EL-BIT-15



Screwdriver (T-15 pin-in-head Torx 6-lobe)

Part Number:
EL-DRV-15

LockView® software

- Add, edit, view and delete users / supervisors and their credentials
- Add, edit and delete CompX eLocks®
- Assign access rights between users / supervisors and CompX eLocks® in the database
- Download, view, save, print, archive and delete audit trails
- Dual credential access available
- Set real time clock
- Time based access restrictions
- Create user groups
- Windows™ based

LockView is a Registered Trademark of CompX International. Windows is a trademark of the Microsoft Corporation. Specifications may vary based on user application.



Part #: 334008-0000-00 Rev A.

Copyright 2023 © CompX Security Products / 847.752.2500 / compx.com / 715 Center St., Grayslake, IL 60030
Any companies and/or products referred to herein are marks or registered trademarks of their respective companies, owners and/or mark holders.

