

TOTAL GAS STATION SECURITY PROGRAM



Tank Commander:
for underground
fuel tank caps



TuBAR high security lock:
for top doors



TuBAR high security lock:
for bottom doors



Pulser security sleeve kit



Totalizer security cover



Multi-point latching system:
for skirt doors

TANK COMMANDER

FIRST & ONLY CARB APPROVED THEFT DETERRENT DEVICE

California Environmental Protection Agency
AIR RESOURCES BOARD

Executive Orders:
VR-101-N, VR-102-N,
VR-103-G, VR-104-G, VR-105-C

CompX
SECURITY PRODUCTS

Crafting quality products
in America since 1903.

TuBAR
High Security Locks.

STOP SKIMMING, IDENTITY THIEF

TuBAR®

high security locks are the proven solution for securing all fuel dispensers.

BASE LOCKS



11/16" lock



15/16" lock

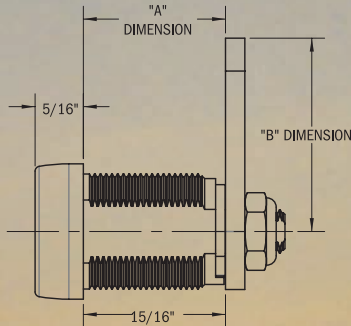
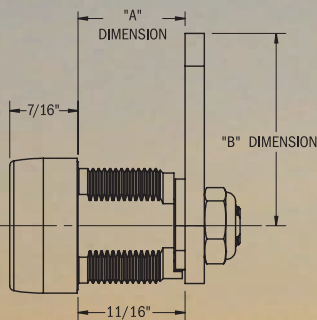

SPECIALIZED 15/16" LOCKS



CRIND upper door lock with attack resistant cam

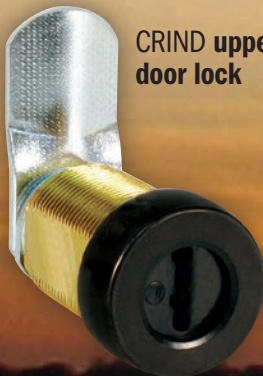

CRIND upper door lock

Encore 300 upper door lock with high security cam

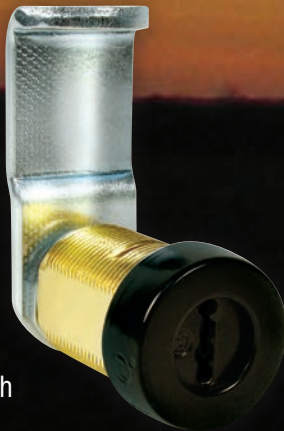

Ovation CAT upper door lock with high security cam

Key Codes

Common, shared across many industries

Registered Key codes assigned by location only by CompX Security Products

Key Control

None - easily duplicated with no restrictions

Replacement keys only available by signature through CompX Security Products; NO key machines commercially available

Key Blanks

Readily available

Only available from factory

Security

Very low

Virtually impregnable to pulling, punching, drilling and other common physical attacks

Lock Construction

Die-cast

Precision machined brass barrel, steel face plate, and dual side bar mechanism assure maximum protection against forced entry

Key compatibility with underground fuel cap

No

TuBAR high security locks can be keyed alike to the Tank Commander

Existing locks vs. TuBAR High Security Locks

EFT AND FREE FLOW VENDING!

HIGH SECURITY KEYS



SPECIALIZED 1 1/16" LOCK



Skirt door lock with attack resistant cam



Vista 2 & 3 CAT door lock

Totalizer fuel security cover

- ◆ Stainless steel
- ◆ Covers and protects "free vend" gears on Gilbarco Advantage
- ◆ Stop replacing pulser drive shafts and stop losing fuel!
- ◆ Most effective with new CRIND and skirt door locks
- ◆ Easy field retrofit
 - Comes with instructions; also available online: comp.com/gssp
 - No drilling



Pulser cover

- ◆ Stops gas theft at Pulser
- ◆ Stainless steel construction
- ◆ Easy to install
- ◆ Protects pulser drive shaft in skirt and vent areas

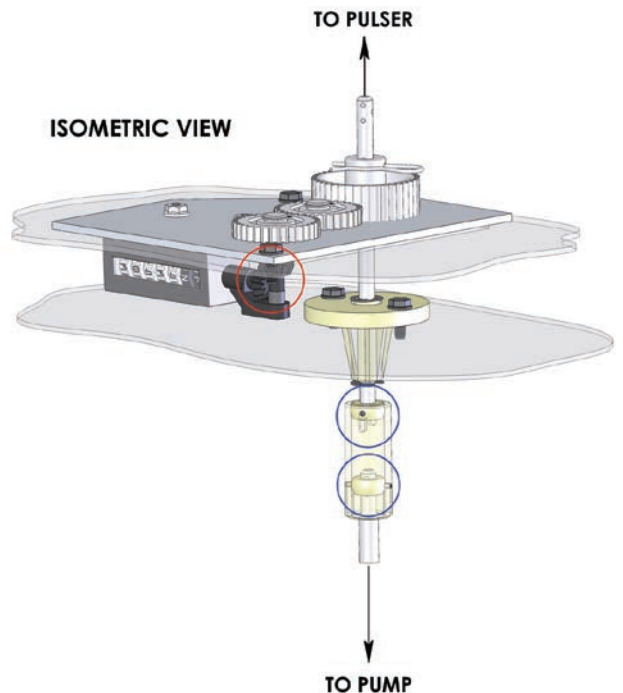
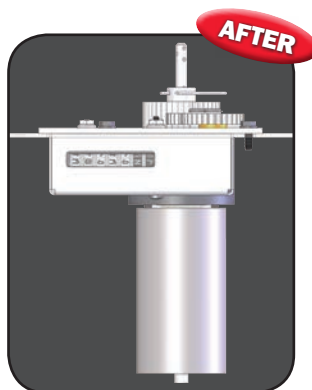
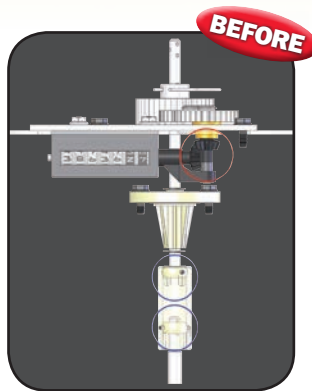
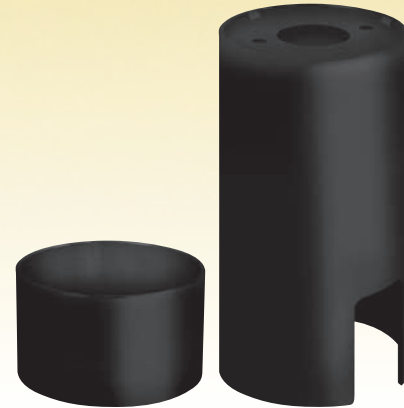

Totalizer and Pulser are specially designed for Gilbarco Advantage.



FUEL THEFT FROM UNDERGROUND TANKS

Tank Commander features:

US Patent 8,240,500.

Tank Commander fits all certified Phase 1 Vapor Recovery Systems: Phil-Tite, OPW, EBW, CNI and EMCO Wheaton

- ◆ Stainless steel construction
- ◆ Vapor recovery seal remains intact
- ◆ Low profile fill cap included
- ◆ Fits common bronze adapters
- ◆ 24/7 protection for diesel and gas

TuBAR high security locking

- ◆ TuBAR® lock for maximum key control
 - No key blanks available except from factory
 - Key series registered to your store(s)
- ◆ Keyed alike available - use the same key for both Tank Commander and dispenser

Keyless convenience

- ◆ Available with heavy duty four number changeable combination padlock
- ◆ Or use existing padlock

TuBAR high security locking



Keyless Convenience

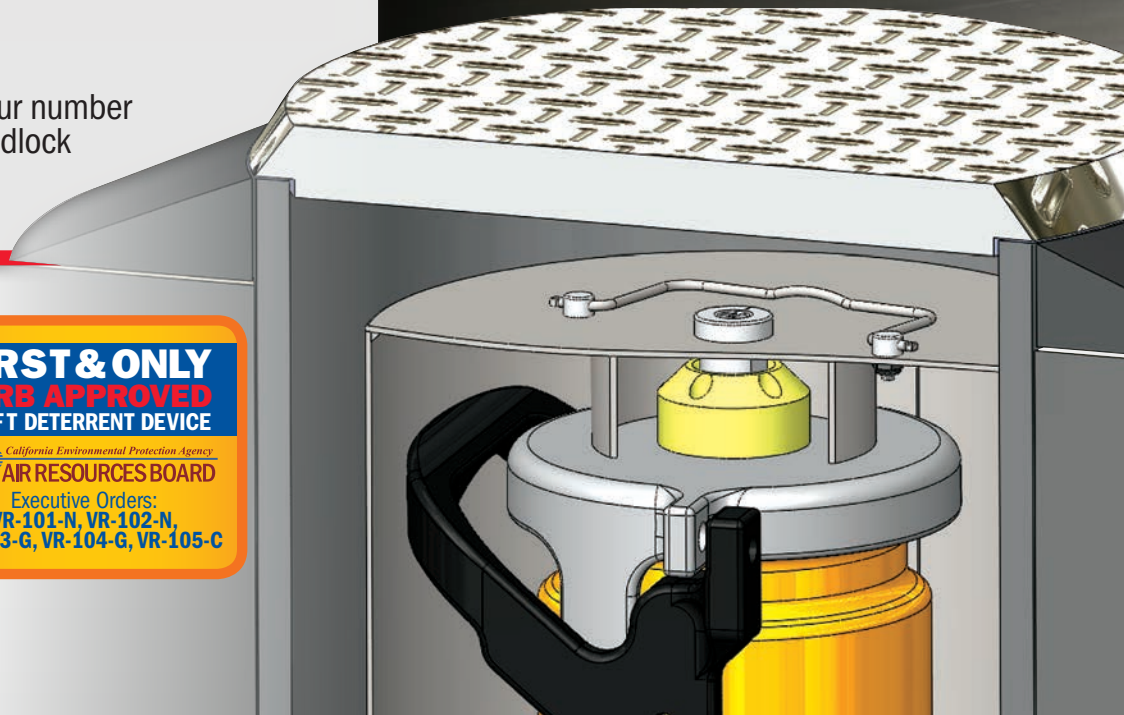

For more information, call 864.297.6655.

Copyright 2014 © CompX Security Products
864.297.6655 / compx.com / PO Box 200, Mauldin, SC 29662

Any companies and/or products referred to herein are marks or registered trademarks of their respective companies, owners and/or mark holders. Products are constantly being improved and therefore may vary or change slightly without notice. Call 864.297.6655 for most up-to-date information.



Reorder #: F2644-006