

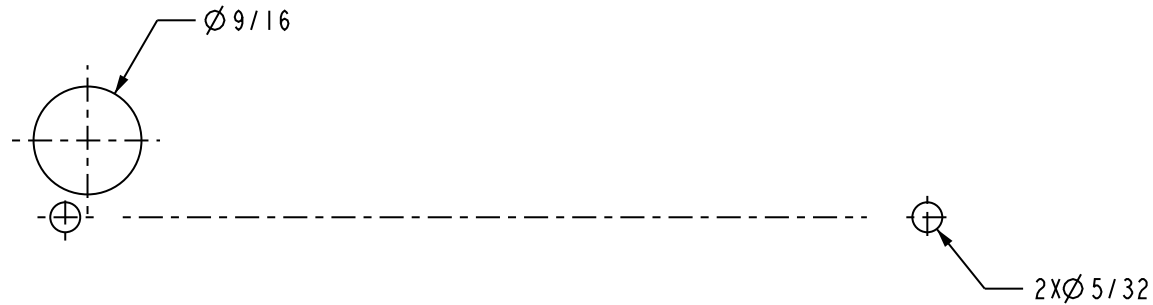



The disclosures and contents of this drawing are confidential and the exclusive property of CompX Fort. This print is not to be copied or reproduced and is furnished for engineering information only. Possession of this print does not give license to manufacture articles shown hereon without written permission. The version fields (VER) must be set to 0 (zero). If not, this drawing is considered uncontrolled and CompX Fort cannot be held responsible for its accuracy. Manufacture of components, and models, shown hereon, is at the vendor's risk.



THIS TEMPLATE IS TO SCALE
 IF THE LINE ABOVE IS NOT 1 INCH LONG
 DO NOT USE TEMPLATE

							PG: 1 OF 1	 GRAYSLAKE, ILLINOIS 60030	PROJ. NO: 570
							SCALE: 1:1		VER: MDL: 0 DRW: 3
							STANDARD TOLERANCES UNLESS OTHERWISE SPECIFIED FRACTION: ±.015 DECIMAL: .XXX = ±.003 .XX = ±.010 .X = ±.015 ANGLES: ±1°	PART NAME: TEMPLATE: MTG. (SNAP ON)	
							 	MATERIAL: NA	
							DRAWN: EV	RELEASE: Concept-Design	
							DATE: Oct 09, 09	DRWG SIZE A	
A	24451	NEW RELEASE	10-09-09	EV	KAZ	FZ	CUST P/N:	PART NO: 332256-0000-00	
REV.	ECO#	DESCRIPTION	DATE	DFTM	CHKD	APVD			